

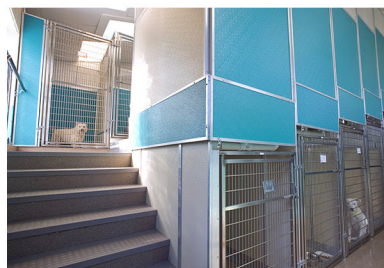

**MASON**  
COMPANY **SINCE 1892**

Trusted Animal Housing Solutions

*Individual Product Spec Sheets*

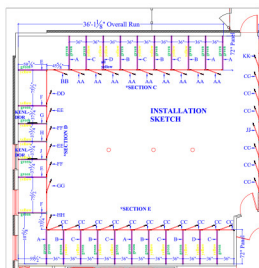









### DOG SOLUTION SPEC SHEETS

|                                  |   |                                      |    |
|----------------------------------|---|--------------------------------------|----|
| Sani-Kennels™                    | 4 | Modular 2-Story Double Deck™ Kennels | 10 |
| Silvis Seal™ and Sani-Slope™     | 5 | Quiet Cottages™ Fiberglass Cages     | 11 |
| Luxury Walk-In Dog Suites        | 6 | ISO-Care™ Quarantine Cages           | 12 |
| K-9 Cabin Double Stacked Systems | 7 | Chain Link Runs                      | 13 |
| Tri-Kennels                      | 8 | Gates & Stall Fronts                 | 14 |
| UltraBase™ Above Floor Kennels   | 9 | In-Depth Product Specs               | 16 |



# Sani-Kennels™

See Page 16 for in-depth details on this product.

Mason's Sani-Kennel™ system is a fully customizable modular kennel design. Materials available include stainless steel, galvanized steel, FRP and Wilsonart. Panels can be made to any height and dimension. Isolation materials available include tempered glass, bonegrid, FRP and Wilsonart. Colorful murals are even available. Available with Mason Company's full line of kennel gates (see specifications). Drawings are for illustrative purposes only.

BACK PANEL EXAMPLE

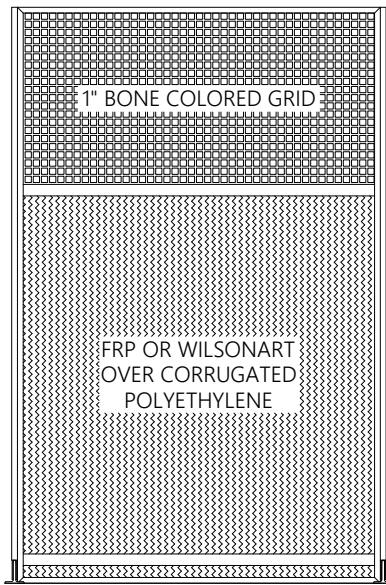

DIVISION PANEL EXAMPLE

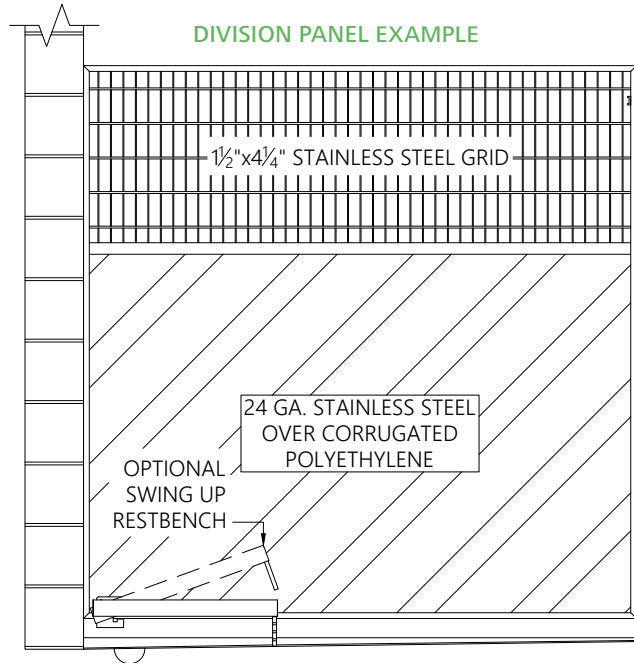

BACK PANEL EXAMPLE

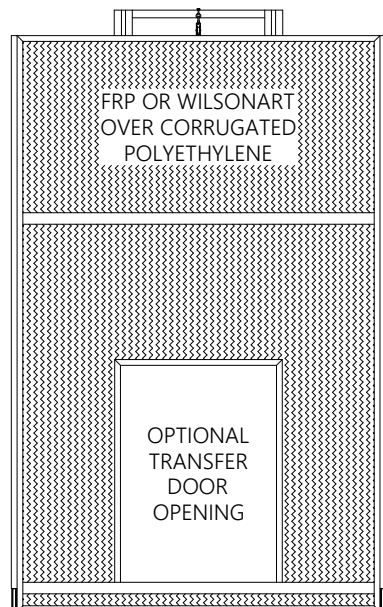

DIVISION PANEL EXAMPLE

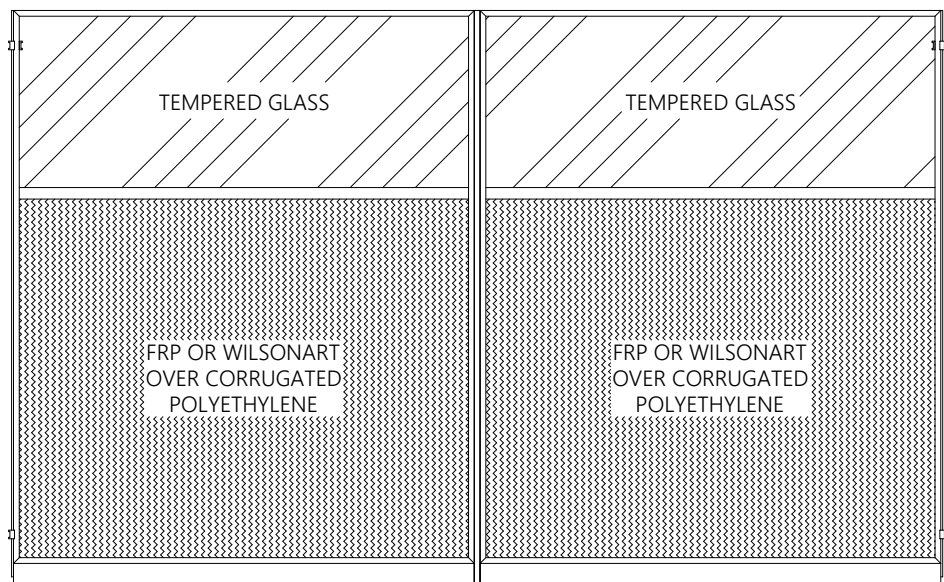



# Silvis Seal™ & Sani-Slope™

See Page 16 for in-depth details on this product.

Superior Floor Mounting AND Leveling Solution  
Exclusively from Mason Company.

The Silvis Seal™ (patent #8707903 & Australian Patent #2012-200-331) and Sani-Slope™ (patent #6152080) are available on the Mason Sani-Kennel's FRP, Wilsonart and stainless steel isolation panels.

## SILVIS SEAL™

Patented Silvis Seal™ is a co-extrusion consisting of a rigid vinyl base and two flexible polyvinyl chloride (PVC) sealing ribs. Adhered to the top of the co-extrusion are two strips of 3M VHB double-sided tape. Each seal shall have an additional end blocker consisting of a strip of closed cell neoprene foam with 3M VHB double-sided tape on one side.

Developed in direct response to customer need, the exclusive Silvis Seal™ barrier provides an entirely new approach to prevent dangerous cross-contamination between kennels. Available only on Mason Company's Sani-Kennel systems, the unique Silvis Seal™ system functions like a dam to create the ultimate watertight, reliable and long-term seal that stops fluid and contaminants from migrating between kennel enclosures.

The patented Silvis Seal™ design configures to the floor slope to create a superior cross-contamination barrier.

- Flexible gasket provides the ultimate watertight barrier underneath division panels
- Protects against deadly diseases
- Conforms to the floor's surface and imperfections as they develop over time
- Provides a second seal beyond silicone for the life of the equipment
- Is not affected by bleach or pressure washing

*No other barrier is more effective, durable or long lasting!*

*Don't put your facility or dogs at risk. Provide the protection that stops the spread of deadly diseases.*

*Watch the video at [www.StopOutbreaksNow.com](http://www.StopOutbreaksNow.com) to learn more about this unique solution.*

## SANI-SLOPE™

The Sani-Slope™ floor mounting system is available only on aluminum-framed isolation panels.

Patented T-flange shall be made of solid extruded 6061-T6 aluminum. T-flange shall be 2-1/2" wide at its base and shall extend upward to a height of at least 3". Patented isolation panel bottom rail extrusion shall be made of solid 6061-T6 extruded aluminum and shall be dimensioned to fit over the T-flange so that the isolation panel can be leveled and secured. T-flange shall be sealed to the floor with provided silicone sealant.

- Provides superior floor leveling with sloped floors
- No need to cut panels to floor slope, avoiding the risks this presents if the slope is different from specifications

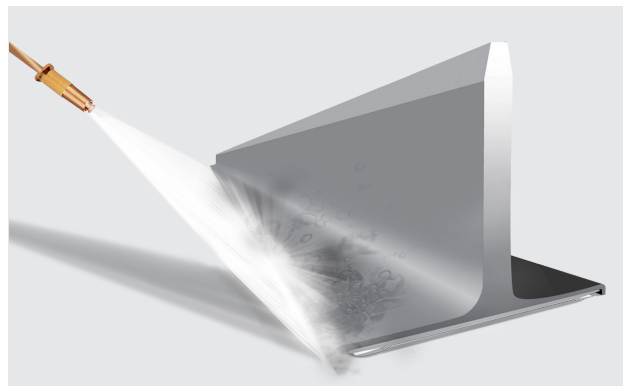

SANI-SLOPE CHANNEL WITH  
SILVIS SEAL

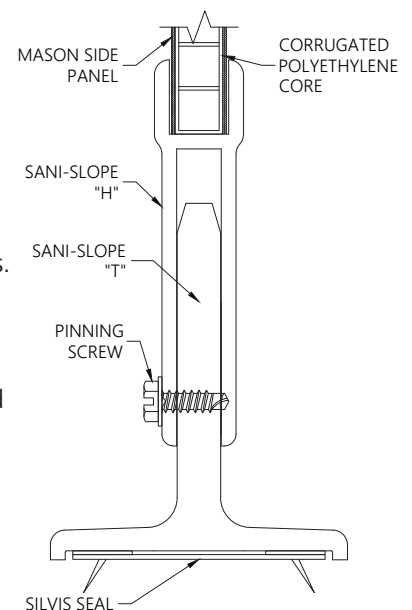

# Luxury Walk-In Dog Suites

See Page 18 for in-depth details on this product.

## DIVISION WALLS

Inner core constructed of expanded polystyrene (EPS) with one of the following side materials:

- FRP sheets .090" thick
- Wilsonart® sheets .090" thick

## SUITE FRONT WALLS

Inner core constructed of expanded polystyrene (EPS) with one of the following inner side materials:

- FRP sheets .090" thick
- Wilsonart® sheets .090" thick

## FRONT WALLS

Available in one of the following materials:

- FRP sheets .090" thick
- Wilsonart® sheets .090" thick
- HardiePlank® (exterior fiber-cement) over a non-Urea-Formaldehyde bonded plywood substrate
- HardiePanel® (exterior fiber-cement)

## 24 GAUGE POLYESTER PAINTED GALVANIZED STEEL DOORS

Tempered glass galvanized steel doors are available as single or dutch doors and include stainless steel door locks

Double pane tempered glass windows are in a bronze anodized aluminum frame

EXTERIOR: HARDIEPLANK,  
HARDIEPANEL, FRP, OR WILSONART  
INTERIOR: FRP OR WILSONART

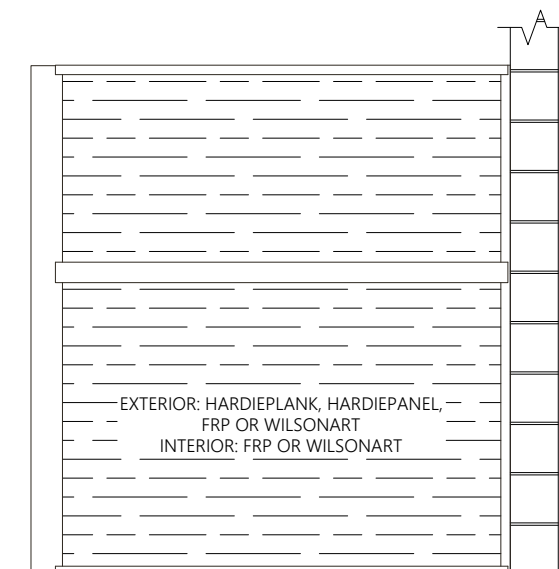
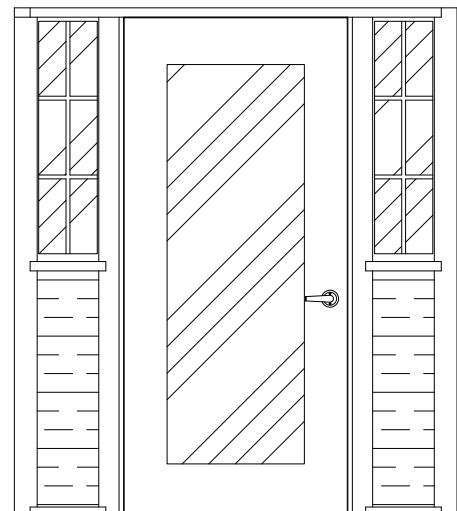
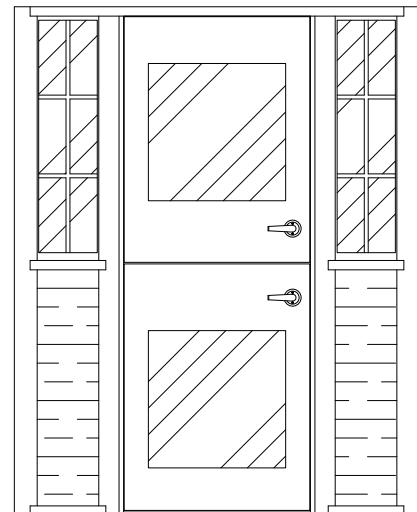
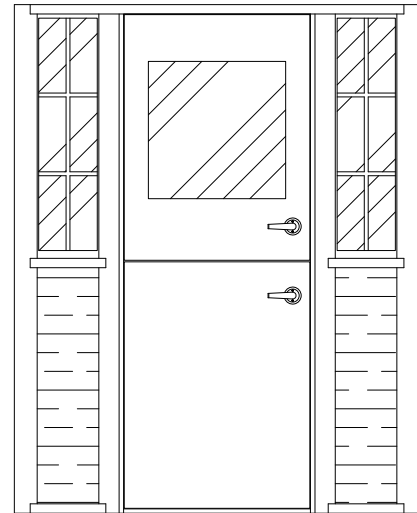



# K-9 Cabin Double Stacked Systems

See Page 18 for in-depth details on this product.

Runs consist of Mason Sani-Kennels (see specifications). Dimensions are customizable. Transfer Doors (see specifications) are available to provide dog access between back-to-back runs or side-to-side. If used, the center trench drain is covered by Mason Aluminum Gutter Covers (see specifications). The upper level runs may be built with or without trench drains that connect by means of PVC piping to the first floor trench drain. Upper level floors are PVC composite board.

K-9 Cabin Double Stacked Systems can be positioned either as free-standing or against a building wall.

Available with Mason Company's full line of kennel gates (see specifications).

Drawings are for illustrative purposes only.

SOLID DIVISION PANEL  
EXAMPLE

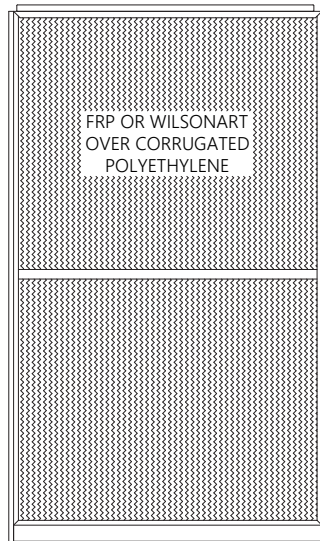

VENTED DIVISION  
PANEL EXAMPLE

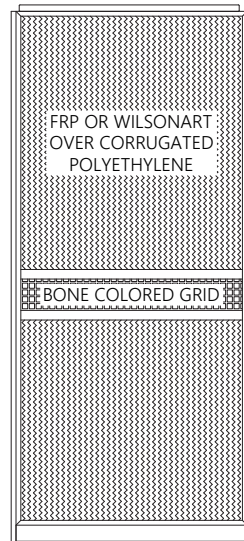

K-9 CABIN GATES & STALL FRONT EXAMPLE

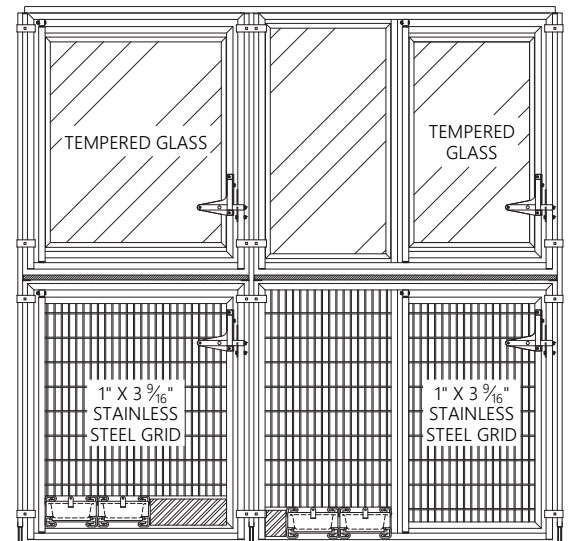

BACK PANEL EXAMPLE

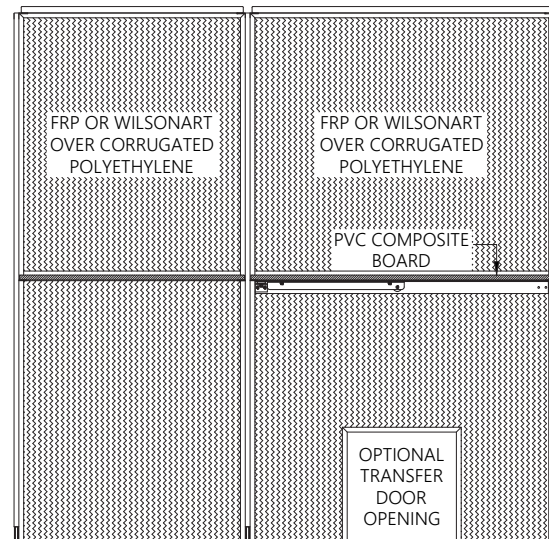

## Tri-Kennels

See Pages 16-17 and the K9 Cabin Double Stacked Systems on Page 18 for in-depth details on this product.

First floor back-to-back runs consist of Mason Sani-Kennel (see specifications) with the lower run of the K-9 Double Stacked System on the back. Dimensions are customizable. Transfer Doors (see specifications) are available to provide dog access between the lower back-to-back runs. Upper level K-9 Cabins must be the same width and depth as the lower level. The upper level run may be built with or without a trench drain that connects by means of PVC piping to the first floor trench drain. Upper level floors may be PVC composite board or fiberglass reinforced plastic.

Available with Mason Company's full line of kennel gates (see specifications).

Drawings are for illustrative purposes only.

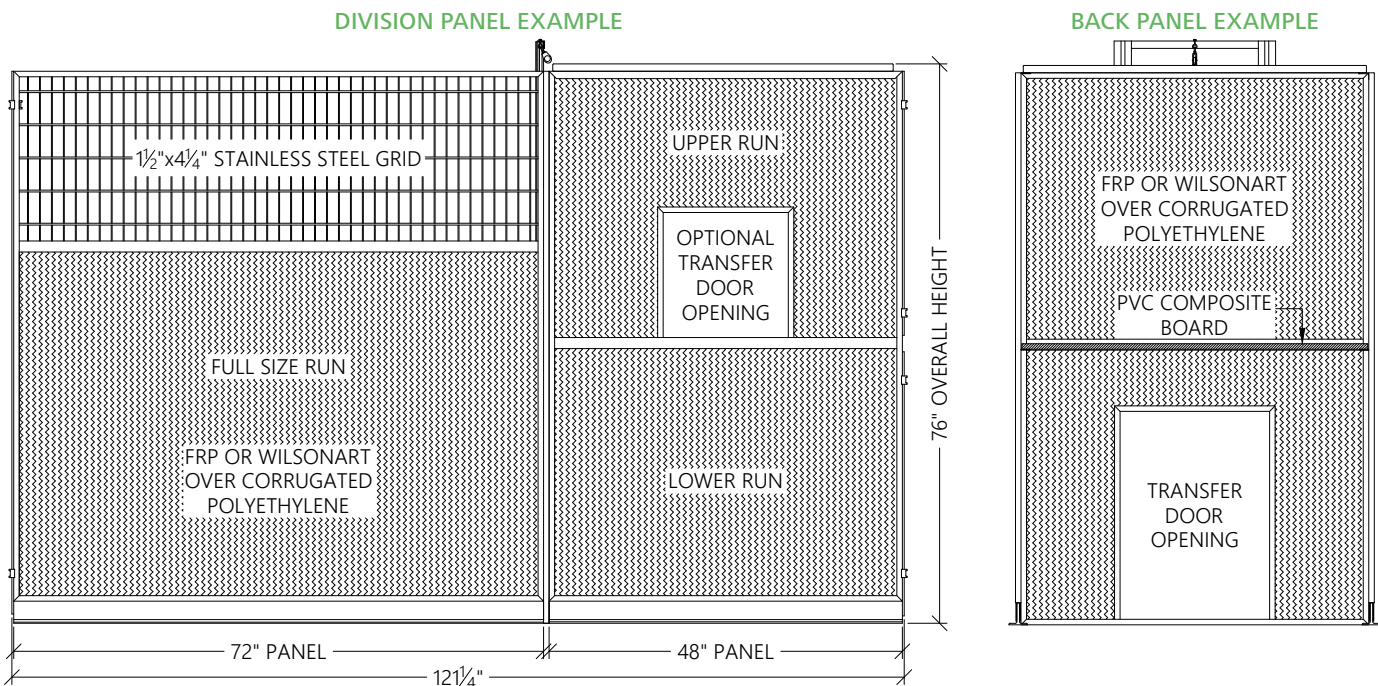



# UltraBase™ Above Floor Kennels

See Page 18 for in-depth details on this product.

Mason's UltraBase™ Above Floor System allows for the installation of indoor kennels in spaces not normally constructed for housing animals and has no floor seam to bend, break or leak.

## AVAILABLE SIZES

- Length: 4', 5', 6', 7', 8'
- Width: 3', 4', 5'
- \*Note: 5' wide model only available in 6' length

## COLORS

- Aurora (Beige)
- Steel Grey

Available with Mason Company's full line of kennel gates (see specifications).

SIDE VIEW EXAMPLE

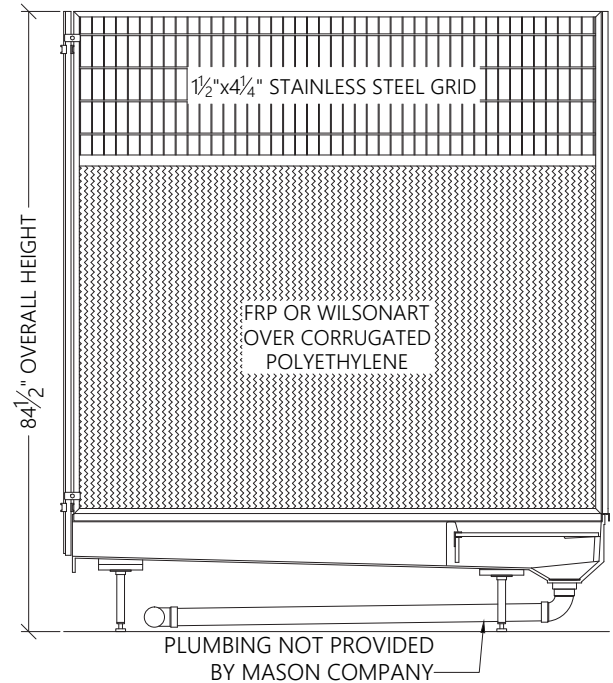

FRONT VIEW EXAMPLE

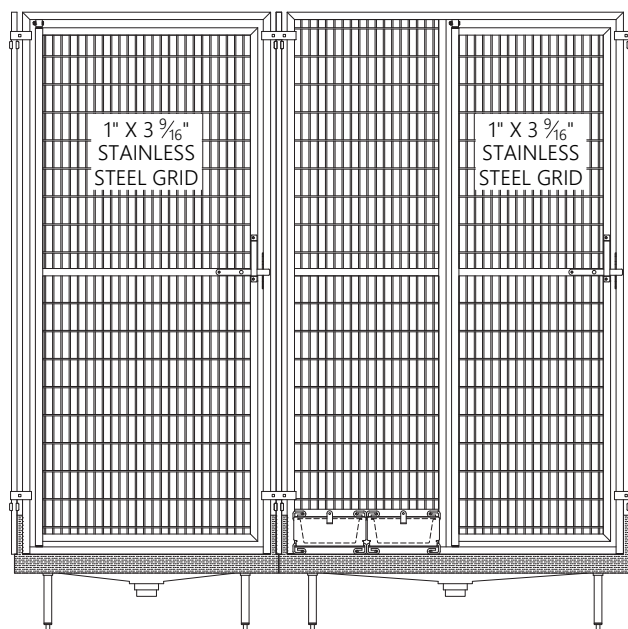

TOP VIEW EXAMPLE

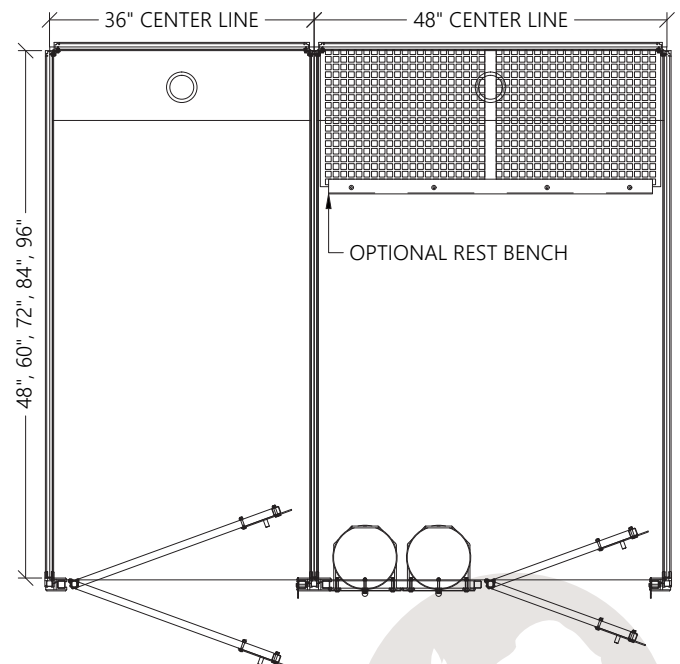

# Modular 2-Story Double Deck™ Kennels

*See Page 18 for in-depth details on this product.*

## BUILDING REQUIREMENTS

- Height: 14' or higher (standard), 12' - 14' (low headroom)
- Width: 12' Minimum for single row system
- 20' Minimum for standard back-to-back system

## STANDARD FEATURES

- First-Floor Run
  - Sani-Kennel System
- Mason transfer door on common back panels
- Upper-Level Run
  - UltraBase™ with built-in floor drain

## AVAILABLE SIZES

- First-Floor Run
  - Length: 6'-10'
  - Width: 3', 4', 5', 6', 7', and 8'
- Upper-Level Run
  - Length: 4'-8' (depending on lower level)
  - Width: 3' or 4'
- Upper Aisle
  - Width: 4'
- Typical Stairway Unit(s)
  - Width: 4' (to be provided by another manufacturer)

## OPTIONS

- Swing-up rest bench

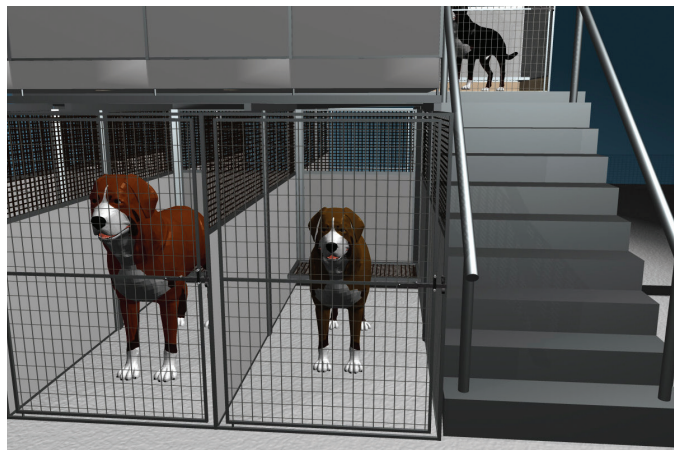
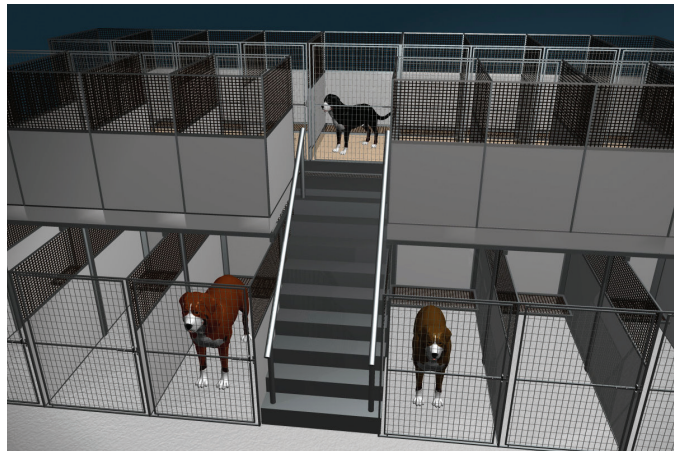
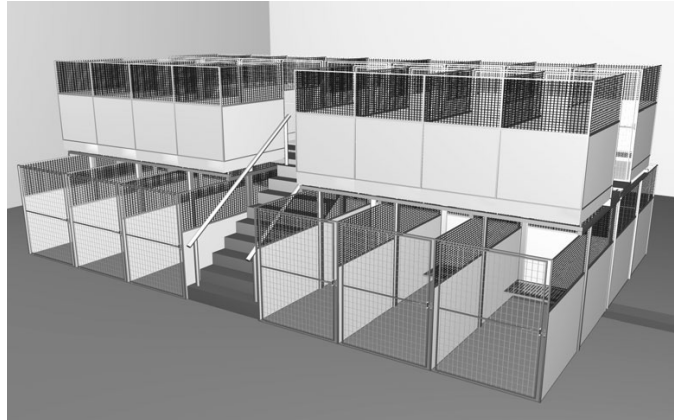



# Quiet Cottages™<sup>TM</sup> Fiberglass Cages

See Page 19 for in-depth details on this product.

## THE QUIET AND WARM ALTERNATIVE TO STAINLESS STEEL

- Manufactured to provide warm, attractive and quiet animal housing areas
- Smooth molded fiberglass construction provides a gentle radius for easy cleaning and promotes a healthy living environment
- Available in several sizes and a variety of configurations
- Some models offered with drains for even quicker cleaning and drying time
- Models offered with drains have a removable 3/4" grid grate
- Manufactured with welded stainless steel doors for durability
- Comes standard with dual point self-latching doors
- Models 1-8 and 12 come standard with swivel type casters for ease of movement
- Units are manufactured with a front debris and liquid retention lip
- Manufactured with a stainless steel support frame to maintain rigidity

Models 9, 10, and 11 all come equipped with the standard drain.

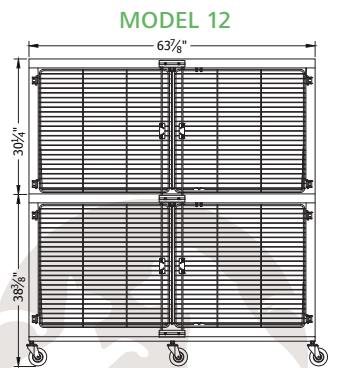
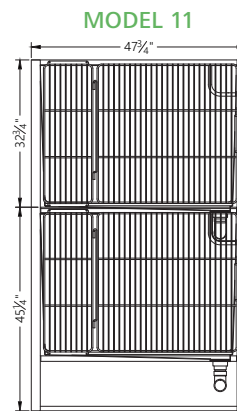
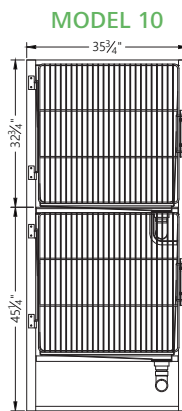
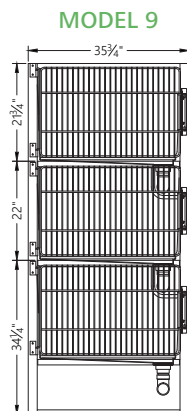
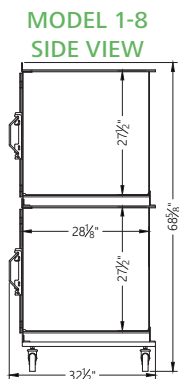
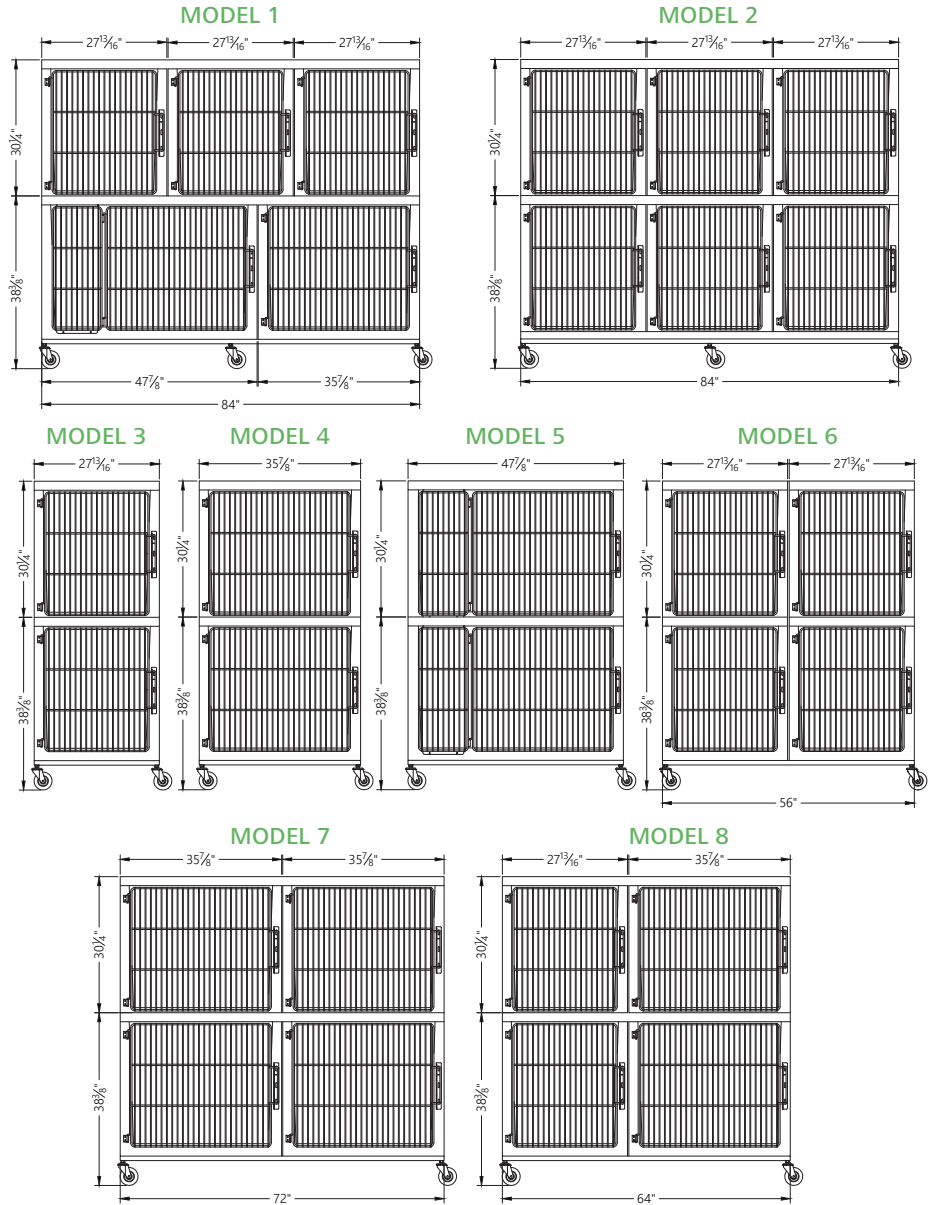

# ISO-Care™ Quarantine Cages

See Page 19 for in-depth details on this product.

## Double Deck ISO-Care Dimensions

### FEATURES

- Warm and quiet fiberglass enclosure
- 2.5" PVC drain outlet
- Elevated Plasticsol-coated mesh floor
- Aluminum-framed tempered glass door
- Interior light
- Exhaust fan
- Aluminum legs
- Ships completely assembled

### EXTERIOR DIMENSIONS

- Single Lower Unit:  
30 1/4" W x 45 7/8" H x 36 5/8" Deep
- Double Deck Unit:  
30 1/2" W x 81 3/4" H x 36 5/8" Deep

### OPTIONS

- ABS Plastic Side Panel  
(Single unit, assembled. Double-deck unit, unassembled.)
- Removable top cover  
(For access to light & fan. In ABS plastic/aluminum frame.)

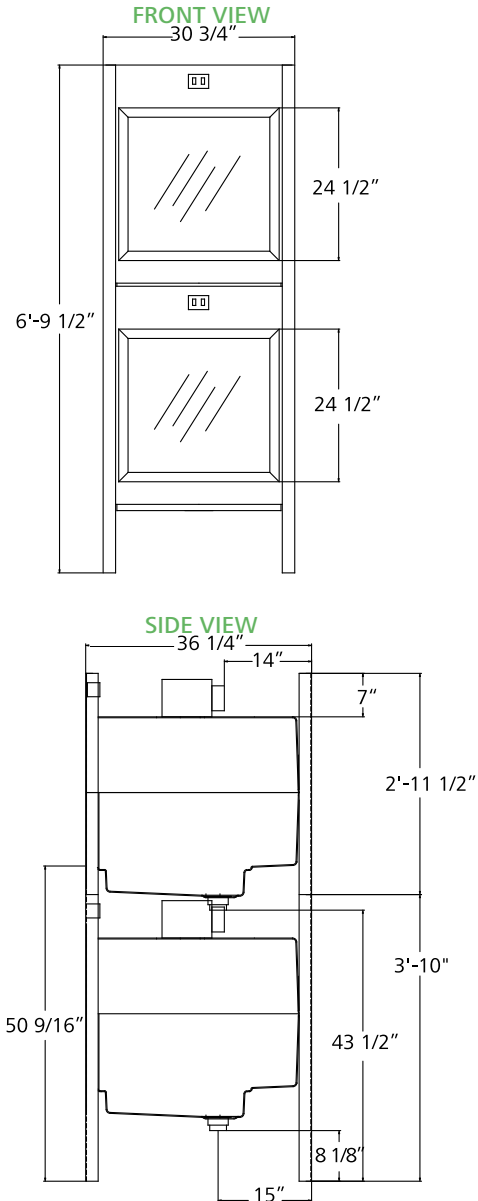

# Chain Link Pens & Runs

Division panels are custom-fit for your application and are tapered to match your floor's slope for proper and accurate installation. Mason's exclusive aluminum isolation channels seal to the floor, helping to prevent cross-contamination.

All framework is made from 1.05" ASTM structural grade steel tubing. All fabric is hand-laced with tempered wire at every intersection to the frame so that it remains tight.

### AVAILABLE PANEL SIZES

Height: 24" - 96"  
 Length: 2' - 14'  
 \*Custom sizes available

### AVAILABLE MESH SIZES

Diamond Size  
 • 1", 1¼", 1½", and 2"  
 Wire Gauge  
 • #9, #11, and #13

### AVAILABLE ISOLATION PANEL MATERIALS

- #24 Gauge Galvanized Steel Sheet
- #24 Gauge Stainless Steel Sheet
- ABS Plastic Blue/Beige Sheet 1/8" Thick

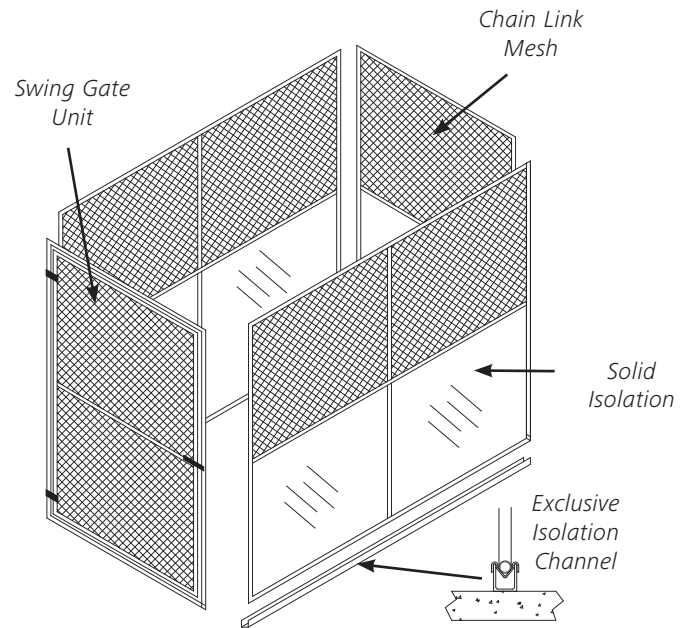

### PANEL OPTIONS

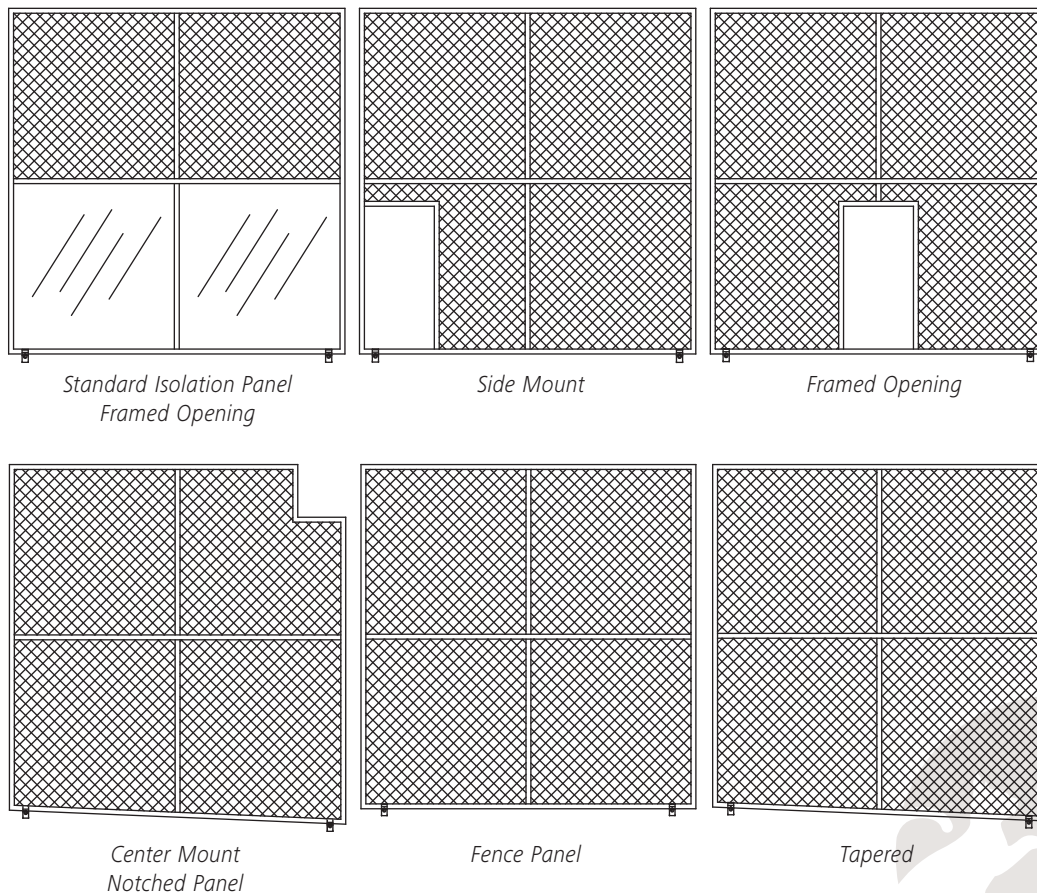



# Gate and Stall Fronts

See Page 17 for in-depth details on this product.

## GATE MATERIALS AVAILABLE INCLUDE:

- Tempered Glass
- Stainless Steel Welded Wire
- Galvanized Welded Wire
- Stainless Steel Welded Wire Slide Gates
- Chain Link
- Combine FRP, Wilsonart and stainless steel isolation with tempered glass or welded wire in any grouping
- Option for FRP or Wilsonart isolation on the “public” side and stainless steel on the inside or “dog” side for maximum aesthetics and maximum security

Drawings are for illustrative purposes only.

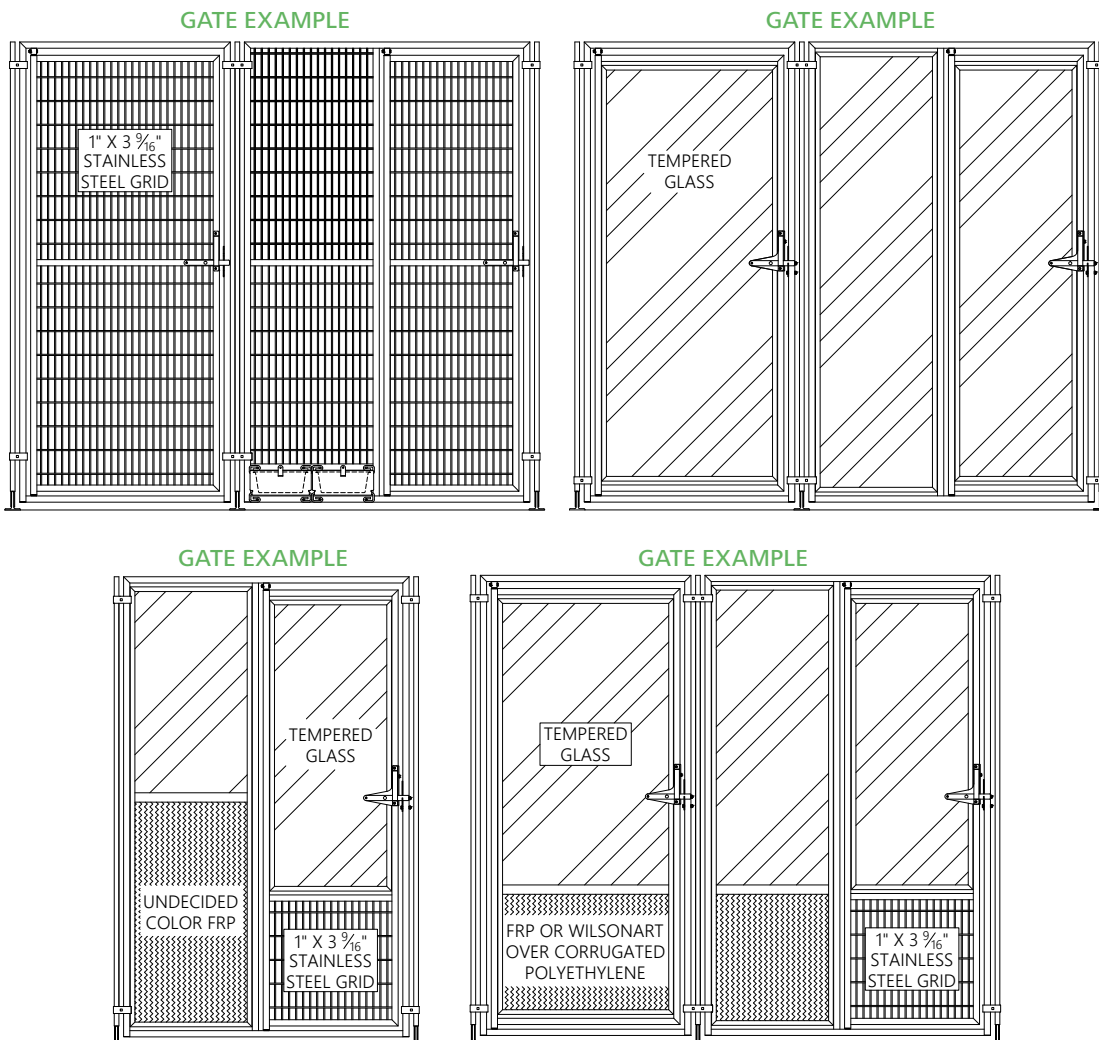







# In-Depth Product Specs

## Dividers & Back Panels

### ALL STAINLESS STEEL ISOLATION PANELS

Perimeter frame and internal bracing shall consist of 1" x 16 gauge (.060" wall) square 304 A-554 welded stainless steel tubing with 180 grit polish. Each corner of the frame shall be TIG welded.

Wire grids shall be constructed of 304 stainless steel wire 1/8" in diameter in the vertical direction with 1 5/8" spacing between wires, and 304 stainless steel wire 1/4" in diameter in the horizontal direction with 6" or less spacing between wires. Horizontal and vertical wires shall be resistance welded at each juncture.

Sheet metal cover on each side to be 20 ga. (.036") 304 stainless steel with 180 grit polish. Between the sheet metal covers is a core material of 1" thick EPS (expanded polystyrene) sheet.

Panel to floor seal mounting angles and panel corner vertical connection angles to be 16 ga. (.060") 304 stainless steel.

### ALUMINUM FRAMED FRP ISOLATION PANELS

Panels shall be constructed of an outer framework of 6063-T52 aluminum U-channel 3/4" x 3/4" x 1/8" thick. Internal braces shall be 6061-T6 aluminum H-channels 1-1/2" x 3/4" x 1/8" thick.

Bottom portion of isolation panel shall be one of the following materials (specify #1, #2, #3):

1. .030" FRP bonded on each side of a .400" HDPE substrate (specify height). Solid panels to be perimeter sealed to the aluminum framework (specify height).
2. High pressure Wilsonart® laminate bonded on each side of a .400" HDPE substrate (specify height). Solid panels to be perimeter sealed to the aluminum framework (specify height).
3. 24 gauge (.024") 304 stainless steel sheet bonded on each side of a .400" HDPE substrate (specify height). Solid panels to be perimeter sealed to the aluminum framework (specify height).

Upper portion shall be one of the following materials (specify #1, #2, #3, #4, #5, or #6):

1" grid polyethylene structural foam 7/16" thick (specify height).

1. .030" FRP bonded on each side of a .400" HDPE substrate (specify height). Solid panels to be perimeter sealed to the aluminum framework (specify height).
2. High pressure Wilsonart® laminate bonded on each side of a .400" HDPE substrate (specify height). Solid panels to be perimeter sealed to the aluminum framework (specify height).
3. 24 gauge (.024") 304 stainless steel sheet bonded on each side of a .400" HDPE substrate (specify height). Solid panels to be perimeter sealed to the aluminum framework (specify height).
4. Hot dipped galvanized welded wire. Wire panels shall be welded at each juncture and shall consist of either 1/8" or 3/16" diameter vertical wires with 1 1/2" spacing between wires and 1/4" or 3/16" diameter horizontal wires with 4 1/4" spacing between wires. Wire panels shall be contained by means of a semi-rigid PVC extrusion inset into the aluminum framework.
5. Stainless steel welded wire. Wire panels shall be welded at each juncture and shall consist of either 1/8" or 3/16" diameter vertical wires with 1 1/2" spacing between wires and 1/4" or 3/16" diameter horizontal wires with 4 1/4" spacing between wires. Wire panels shall be contained by means of a semi-rigid PVC extrusion inset into the aluminum framework.

6. Glass panels shall be 1/4" tempered glass held in place by a semi-rigid PVC extrusion inset into the aluminum framework.

### SANI-SLOPE™ ALUMINUM SLOPED FLOOR MOUNTING SYSTEM AVAILABLE ON ALUMINUM FRAMED ISOLATION PANELS

Patented T-flange shall be made of solid extruded 6061-T6 aluminum. T-flange shall be 2-1/2" wide at its base and shall extend upward to a height of at least 3".

Patented isolation panel bottom rail extrusion shall be made of solid 6061-T6 extruded aluminum and shall be dimensioned to fit over the T-flange so that the isolation panel can be leveled and secured. T-flange shall be sealed to the floor with provided silicone sealant.

### SILVIS SEAL™ (AVAILABLE ON ALUMINUM FRAMED FRP ISOLATION PANELS)

Patented Silvis Seal™ shall be a co-extrusion consisting of a rigid vinyl base and two flexible polyvinyl chloride (PVC) sealing ribs. Adhered to the top of the co-extrusion shall be two strips of 3M VHB double-sided tape. Each seal shall have an additional end blocker consisting of a strip of closed cell neoprene foam with 3M VHB double-sided tape on one side.

### CHAIN LINK DIVIDERS AND BACK PANELS FRAMEWORK

Shall be made from Gatorshield® ASTM A500 structural grade steel tubing, 1.050" pipe size O.D. 0.94 pounds per foot weight ( $\pm 5\%$ ), 50,000 p.s.i. minimum yield strength. Lightweight tubing or galvanized schedule 40 pipe not permitted. The exterior surface shall be in line, hot-dip galvanized in molten zinc (zinc conforming to ASTM B-6) to a nominal weight of 0.8 ounces per square foot of surface as measured by the methods of ASTM A90. Additionally, the tubing shall be coated with a chromate rust inhibitor and a clear polymeric top coat. The interior tubing surface shall be completely and evenly coated with a full zinc-based galvanizing compound to ensure maximum corrosion-resistant integrity. The resulting product will exhibit corrosion resistance at least 3 times (300%) greater than galvanized schedule 40 pipe (ASTM A-53-8) when tested in accordance with ASTM B117 standards.

All corners on the frames shall be precision welded, ground, cleaned and given two zinc-rich coatings containing at least 95% pure zinc when dried and a single top coat of silver Rustoleum®. Panels installed on graded floors shall be manufactured to follow the slope. Ex: if taper in floor is 1-1/2" over 6' span, slope equals 1/4" per lineal foot of panel.

### FABRIC & MESH

Fabric shall be woven from smooth-seal galvanized zinc wire, either (#9, #11, or #13) gauge. The zinc coating shall be a minimum of 1.2 ounces of pure zinc per square foot of wire surface in accordance with ASTM A-641-91. All fabric shall be manufactured undersized by 1/4" to be fitted in the tubular frame.

Fabric shall be stretched taut to the inside of the centerline of the frame under tension and shall be laced with #13 gauge wire at each intersection to the frame so that it remains tight. There shall be tie wires secured to all vertical braces.

There shall be a uniform diamond square mesh of (2", 1-1/2", 1-1/4" or 1") between the parallel sides after weaving. All fabric ends shall be knuckled for safety.



### ISOLATION PANELS

Upper chain link and bottom solid portions shall be separated by a horizontal brace made from (1.050" or .815") O.D. tubing.

Bottom portion of isolation panel shall be 48" high (other heights available), shall be installed with 3/4" wide keyhole clamps spaced on 8" center and shall be one of the following materials (specify #1, #2, or #3):

1. Stainless steel sheets of #24 gauge (18-8 type 304-2B) shall be installed with #22 gauge stainless steel keyhole clips and spot-welded.
2. Galvanized steel sheets of #24 gauge shall be installed with #22 gauge stainless steel keyhole clips and spot welded.
3. ABS Sheet (Acrylonitrile Butadiene Styrene) 1/8" thick shall be installed with aluminum keyhole clamps and stainless steel bolts. Recommended for indoor use only.

FRP sheets of .030" FRP bonded on each side of a .400" HDPE substrate (specify height) in an outer framework of 6063-T52 aluminum U-channel 3/4" x 3/4" x 1/8" thick. Solid panels to be perimeter sealed to the aluminum framework.

Isolation channel shall be extruded 6063-T5 aluminum. Two panel hangers shall be provided for channels up to 10' long. Three panel hangers are used for panels over 10' long. Channels shall be secured and sealed to the floor with provided silicone sealant.

### Gates And Stall Fronts

#### TEMPERED GLASS GATE

Outer framework and latch consists of same as Stainless Steel Gate Unit. Glass panels shall be 1/4" tempered glass held in place by a semi-rigid PVC extrusion inset into the aluminum framework of 6063-T52 aluminum U-channel 3/4" x 3/4" x 1/8" thick. Panels shall be secured to the frame by means of stainless steel fasteners.

#### STAINLESS STEEL GATES AND STALL FRONTS

Gate and stall front frames shall consist of 1" x 16 gauge (.060" wall) square 304 A-554 welded stainless steel tubing with 180 grit polish. Each corner of the frame shall be TIG welded.

Gate grids shall be constructed of 304 stainless steel wire 3/16" in diameter in the vertical direction with 15/16" spacing between wires, and 304 stainless steel wire 3/16" in diameter in the horizontal direction with 3-5/8" or less spacing between wires.

Horizontal and vertical wires shall be resistance welded at each juncture and each wire shall insert into the framework.

Gate Hinges shall consist of two 3/8" diameter stainless steel hex head screws which shall be threaded into stainless steel tapped plugs inserted into the top and bottom of the door frame. Each plug shall contain a nylon pivot bushing for smooth precision rotation.

Patented stainless steel two-way latch shall open both outward and inward. The latch shall secure automatically when gate is closed from the outward position and from the inward position it shall be able to latch and open from the inside of kennel. It shall be designed to accept a padlock. The two-way latch bar, the latch catch, and the swing pendant shall be made from 304 stainless steel.

Solid internal panels (as required) shall be 1/4" tempered glass or 1/2" FRP framed in an outer framework of 6063-T52 aluminum U-channel 3/4" x 3/4" x 1/8" thick. Panels shall be secured to the frame by means of stainless steel fasteners.

### STAINLESS STEEL SLIDE GATES

Gate and stall front frames shall consist of 1" x 16 gauge (.060" wall) square 304A-554 welded stainless steel tubing with 180 grit polish. Each corner of the frame shall be TIG welded.

Gate grids shall be constructed of 304 stainless steel wire 3/16" in diameter in the vertical direction with 15/16" spacing between wires, and 304 stainless steel wire 3/16" in diameter in the horizontal direction with 3-5/8" or less spacing between wires. Horizontal and vertical wires shall be resistance welded at each juncture and each wire shall insert into the framework.

Gate hanger brackets shall be 14 gauge (.075" thick) 304 stainless steel. It shall have a 3/8" dia. 304 stainless steel clevis pin TIG welded to one end. Each hanger bracket shall have a 1 1/8" diameter double shielded ball bearing roller for low friction operation.

The gate assembly shall be suspended from a 14 gauge (.075" thick) 304 stainless steel track and shall be constrained at the bottom by a 16 gauge (.060" thick) 304 stainless steel channel and a 1" x 16 gauge (.065" wall) square 304 A-554 welded stainless steel tube.

Stainless steel latch shall secure automatically when gate is closed and it shall be able to latch and open from the outside and inside of kennel. It shall be designed to accept a padlock. The latch plate, the latch retainer, and the slide pendant shall be made from 304 stainless steel.

Solid internal panels (as required) shall be 1/4" tempered glass or 1/2" FRP framed in an outer framework of 6063-T52 aluminum U-channel 3/4" x 3/4" x 1/8" thick. Panels shall be secured to the frame by means of stainless steel fasteners.

### GALVANIZED WELDED WIRE GATES AND STALL FRONTS

Gate frame and gate shall consist of 1" x 16 gauge (.060" wall) square HRPO ASTM A513 tubing. Each corner of the frame shall be TIG welded. Gate and frame shall be hot dip galvanized in accordance with ASTM A123, inside and out. Gate grids shall be constructed of cold rolled steel wire 3/16" in diameter in the vertical direction with 15/16" spacing between wires, and cold rolled steel wire 3/16" in diameter in the horizontal direction with 3-5/8" or less spacing between wires. Horizontal and vertical wires shall be resistance welded at each juncture. Each wire grid shall be inserted into the outer and internal 1" framework.

Hinges shall consist of two 3/8" diameter stainless steel hex head screws that shall be threaded into stainless steel tapped plugs inserted into the top and bottom of the door frame. Each plug shall contain a nylon pivot bushing for smooth precision rotation.

Patented stainless steel two-way latch shall open both outward and inward. The latch shall secure automatically when gate is closed from the outward position and from the inward position it shall be able to latch and open from the inside of kennel. It shall be designed to accept a padlock. The two-way latch bar, the latch catch, and the swing pendant shall be made from 304 stainless steel.

### CHAIN LINK GATES AND STALL FRONTS

Mesh shall be uniform (2", 1-1/2", 1-1/4", or 1") diamond squares in (#9, #11, or #13 gauge) smooth-Seal wire (refer to chain link product line specifications).

Gate hinges shall be made from malleable cast iron in accordance with ASTM A-47-77 Class 32510. Each clamp shall have two halves joined by 5/16" x 1-3/4" hot-dipped galvanized carriage bolt and nut. Hinges are factory installed and can be field adjusted if necessary.

### *Luxury Walk-In Dog Suites*

Each Suite shall be constructed of division walls constructed of an inner core of expanded polystyrene (EPS) with one of the following materials bonded to the sides:

- FRP sheets .090" thick
- Wilsonart® sheets .090" thick

Suite front wall sections shall be constructed of an inner core of expanded polystyrene (EPS) with one of the following materials bonded to the inner side:

- FRP sheets .090" thick
- Wilsonart® sheets .090" thick

The front wall sections outer side can be one of the following materials:

- FRP sheets .090" thick
- Wilsonart® sheets .090" thick
- HardiePlank® (exterior fiber-cement) over a non-Urea-Formaldehyde bonded plywood substrate
- HardiePanel® (exterior fiber-cement)

Each panel to be framed with bronze anodized aluminum extrusions secured with #10-32 x 5/8" TEK stainless steel screws. Extrusions may be anchored to the wall and floor with #12 x 2" Hex head stainless steel screws or 1/4" x 1-3/4" Tapcons.

Doors shall be 24 gauge polyester painted galvanized steel surrounding a polyurethane core with aluminum internal stiles and rails bonded to the core for rigidity. Door jambs to be 16 gauge painted steel with an ADA approved aluminum sill. Door glass to be tempered. Doors are available as single or dutch doors. Door locks to be stainless steel.

Windows are to be double pane tempered glass in a bronze anodized aluminum frame.

### *K-9 Cabin™ Double Stacked Systems*

First floor back-to-back runs consist of Mason FRP Sani-Kennels (see specifications) that can be furnished in widths of 3' and 4'. Combinations of these widths can be specified within a system. Counterweighted Transfer Doors (see specifications) are available to provide dog access between the back-to-back runs. Center trench drain (manufactured by others) is covered by Mason Aluminum Gutter Covers (see specifications). Upper level kennels must be the same width and depth as the lower level runs. The upper level runs may be built with or without built-in drains that connect by means of PVC piping to the first floor trench drain. Upper level floors may be 304 SS or molded composite.

Single Row systems, designed for use in rooms that are too narrow to accommodate first floor back-to-back runs, contain a single row of first floor runs topped by one row of upper level runs. Single Row can be positioned either as free-standing or against a building wall.

Kennel gates on both levels are Mason stainless steel swing gates, galvanized welded wire gates, or chain link swing gates (see specifications).

### *Ultrabase™ Above Floor System*

Base unit shall be constructed of molded, solid surface Lite-Gran® fiberglass-reinforced plastic with a 1/2" thick honeycomb core in the main floor area. The base unit shall contain a 2" PVC drain with removable snap-in hair guard. 3/4" plywood pads covered by fiberglass-reinforced plastic shall be molded into each corner of the underside of the base unit.

UltraBase™ legs shall be Super Gatorshield™ ASTM A500

structural steel tubing, threaded at one end and having a threaded insert at the opposite end. Four stainless steel bolts with lock nuts and adjustable floor pads shall be provided for insertion into each threaded insert to provide a means for leveling the base units. Units shall have molded ledges on each side to provide a secure mounting position for (optional) resting bench.

Optional resting bench shall consist of one of the following:

1. 1" grid polyethylene structural foam 7/16" thick with a full-length 2" x 2" x 1/8" 6061-T6 aluminum angle covering the front side that permits the mounting of a front debris guard constructed from 1" grid polyethylene structural foam, and 1-1/2" x 1-1/2" x 1/8" 6061-T6 angle stiffeners along the underside.
2. Bench surface shall be constructed of .030" FRP or High Pressure Wilsonart Laminate bonded on each side of a .400" HDPE substrate. The outer framework of the bench shall consist of 6063-T6 aluminum extrusions. All intersections are to be secured with aluminum angles and stainless steel flat head screws. The vertical front debris guard shall consist of 1" grid polyethylene structural foam 7/16" thick and run the width of the bench. The debris guard shall be connected to the bottom of the bench with stainless steel bolts and nuts. Bench shall be designed to pivot up and remain in the upright position until it is manually released and lowered. Bench shall be provided with all necessary hardware for installation.

### *Modular 2-Story Double-Deck™*

#### **KENNELS SYSTEM**

Mason's patented Modular 2-Story Double Deck™ Kennels (#6,021,739 & #6,568,350) are available in a variety of lengths and widths. First floor back-to-back runs are Mason FRP Sani-Kennels (see specifications – FRP only on Double Decks) that can be furnished in widths of 3', 4', 5', 6', 7', 8', or 9'. Combinations of these widths can be specified within a Double-Deck™ module. Counterweighted Transfer Doors (see specifications) are furnished on most first floor runs to provide dog access between the back-to-back runs. Center trench drain (manufactured by others) is covered by Mason aluminum-frame swing up rest benches (see specifications). Upper level kennels consist of two rows of Mason UltraBases™ (see specifications) in widths of 3' or 4'. The upper level runs face a 4' wide molded fiberglass center aisle with built-in drains that connect by means of PVC piping to the first floor trench drain.

Single row Double-Deck™ systems, designed for use in rooms that are too narrow to accommodate first floor back-to-back runs, contain a single row of first floor runs topped by one row of upper level runs and a molded fiberglass aisle. Single row Double-Deck™ systems can be positioned either as free-standing or against a building wall.

Kennel gates on both levels are Mason tempered glass gates, stainless steel swing gates, galvanized welded wire gates, or chain link swing gates (see specifications).

Double-Deck™ structural support package includes all required posts, hardware, walkways, drains, and piping.

Stairway(s) are not included in Mason's quotation and should be obtained locally. Mason personnel will coordinate the dimensioning and installation of the stairway(s) with the local supplier.

#### **MOVABLE PANEL SYSTEM**

System to be comprised of up to 3 panels. Panels shall be connected by hinges to allow the system to be folded for storage and expanded to various configurations. System shall be supplied

with necessary hardware to allow the ends of the system to be secured to nearby walls. The panels shall be movable by means of swivel casters 3" in dia. Panels can be built with pass through stainless steel pass through gates.

Perimeter frame, caster mounting, and internal bracing shall consist of 1" x 16 gauge (.065" wall) square 304 A-554 welded stainless steel tubing with 180 grit polish. Each corner of the frame shall be TIG welded.

Solid internal panels (as required) shall be one of the following materials (specify #1, #2, #3, #4):

1. 030" FRP bonded on each side of a .400" HDPE substrate (specify height). Solid panels to be perimeter sealed to the aluminum framework (specify height).
2. High pressure Wilsonart® laminate bonded on each side of a .400" HDPE substrate (specify height). Solid panels to be perimeter sealed to the aluminum framework (specify height).
3. 24 gauge (.024") 304 stainless steel sheet bonded on each side of a .400" HDPE substrate (specify height). Solid panels to be perimeter sealed to the aluminum framework (specify height).
4. 24 gauge (.024") Galvanized steel sheet bonded on each side of a .400" HDPE substrate (specify height). Solid panels to be perimeter sealed to the aluminum framework (specify height).

Panels shall be secured to the frame by means of stainless steel fasteners and aluminum connector brackets.

Wire grids shall be constructed of 304 stainless steel wire 1/8" in diameter in the vertical direction with 1 5/8" spacing between wires, and 304 stainless steel wire 1/4" in diameter in the horizontal direction with 6" or less spacing between wires. Horizontal and vertical wires shall be resistance welded at each juncture.

### **Fiberglass Quiet Cottages™**

#### **WITH DRAINS**

Fiberglass enclosure shall be constructed of molded polyester fiberglass with solid surface composite 1/8" thick. Units shall have a 1/4" high retention lip across the front edge of the floor area. Interior raised floor shall consist of 1" grid polyethylene structural foam 7/16" thick. Each individual unit shall contain a 2" PVC drain with removable snap-in hair guard, unless specifically ordered without drains.

Door shall be constructed of 304 stainless steel wire. Perimeter and horizontal wires to be 5/16" diameter with 8 7/8" spacing between wires. Vertical wire to be 3/16" diameter with 1" spacing between wires. All wires shall be welded at each juncture. The latch shall secure automatically when gate is closed and shall be designed to accept a padlock. Door latch components to be 14 gauge (.075") stainless steel and shall secure the door at two points. Door latch shall be on right side. It shall be designed to accept a padlock.

Support legs shall be 2" x 2" x 1/8" 6063-T5 aluminum angle. A threaded tinnerman and a stainless steel bolt shall be provided at each bottom corner to provide a means for leveling the unit.

Optional side and bottom front trim panels shall be a single thickness (.090") sheet of FRP secured in place with rigid vinyl extrusions and stainless steel screws.

#### **WITHOUT DRAINS**

Fiberglass enclosure shall be constructed of molded polyester fiberglass with solid surface composite 1/8" thick. Units shall have a 1/4" high retention lip across the front edge of the floor area. Each unit shall have a 1/4" polypropylene top panel.

Door shall be constructed of 304 stainless steel wire. Perimeter and horizontal wires to be 5/16" diameter with 8 7/8" spacing between wires. Vertical wire to be 3/16" diameter with 1" spacing between wires. All wires shall be welded at each juncture. The latch shall secure automatically when gate is closed and shall be designed to accept a padlock. Door latch components to be 14 gauge (.075") stainless steel and shall secure the door at two points. Door latch shall be on right side. It shall be designed to accept a padlock.

Unit support frame shall consist of 1" x 16 gauge (.060" wall) square 304A-554 welded stainless steel tubing with 180 grit polish. Each corner of the frame shall be TIG welded. Each frame will have 1/2-1/3 internal threaded nuts as required.

Casters shall be 4" x 15/16" polyolefin threaded stem swivel type.

#### **ISO-Care™ Isolation Unit**

Fiberglass enclosure shall be made of fiberglass-reinforced plastic construction consisting of 1-1/2 oz. glass mat, isophthalic resin with UV inhibitor, and 6-8 mil gel coat finish on entire interior surface and the front exterior surface. Interior raised floor shall be plastisol-coated expanded metal. Door shall be of tempered glass with aluminum frame. Door latch shall be on right side (facing unit) unless left side is specified. Support legs shall be 2" x 2" x 1/8" 6063-T5 aluminum angle.

#### **Top Covers**

##### **STAINLESS STEEL TOP COVERS**

Perimeter frame and internal bracing shall consist of 1" x 16 gauge (.065" wall) square 304 A-554 welded stainless steel tubing with 180 grit polish. Each corner of the frame shall be TIG welded.

Wire grids shall be constructed of 304 stainless steel wire 1/8" in diameter in both directions with 3" spacing between wire centerlines. All wires shall be resistance welded at each juncture. Wire grid shall be TIG welded securely to the square tubing framework.

##### **GALVANIZED STEEL TOP COVERS**

Perimeter frame and internal bracing shall consist of 1" x 16 gauge (.060" wall) square HRPO ASTM A513 tubing. Each corner of the frame shall be TIG welded. Wire grids shall be constructed of cold rolled steel wire 1/8" in diameter in both directions with 3" spacing between wire centerlines. All wires shall be resistance welded at each juncture. Wire grid shall be TIG welded securely to the square tubing framework.

Top cover shall be hot dip galvanized in accordance with ASTM A123, inside and out.

##### **BONE GRID TOP COVERS**

1" grid polyethylene structural foam 7/16" thick shall be inset into an aluminum framework of 6063-T52 aluminum U-channel 3/4" x 3/4" x 1/8" thick.

##### **CHAIN LINK TOP COVERS**

Please refer to the specifications listed in the Chain Link Product Line Framework and Fabric & Mesh sections.

##### **BLACK MESH**

2" x 2" square opening polypropylene mesh. Mesh shall be held in place using plastic cable ties.

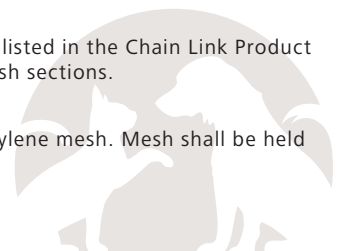



# IN-DEPTH PRODUCT SPECS

## Transfer Doors

Vertical sliding doors shall be one of the following materials (specify, #1, #2, #3):

1. 1/4" thick, low-stress translucent polypropylene.
2. 1/4" thick Polymetal.
3. 0.100" thick Aluminum.

Channels shall be solid extruded aluminum 6063-T6. Doors are raised or lowered by pulling or releasing a 3/32" stainless steel wire cable that is secured to the top of the door. Transfer doors come equipped with cable, "S" hooks, pulleys, screw-eyes, and all necessary hardware for easy installation.

Transfer doors are available in three standard sizes: Regular – for openings up to 29" high by 12" wide. Large – for openings up to 29" high x 17" wide. Extra large – for openings up to 34" high x 17" wide. Other sizes available. Optional cable guards shall be made of 0.100" aluminum sheet and shall be fastened to the channels with stainless steel screws.

### INSULATED TRANSFER DOOR

Vertical sliding doors shall be 1/4" thick, Polymetal. Each door shall have an 18 gauge (.048") aluminum cover. The cover shall be held in place with stainless steel barrel bolts and screws.

The interior space of the aluminum cover shall be filled with .5" thick EPS (expanded polystyrene foam) with an R value of 2.085.

Channels shall be solid extruded aluminum 6063-T6. Doors are raised or lowered by pulling or releasing a 3/32" stainless steel wire cable that is secured to the top of the door. Transfer Doors come equipped with cable, "S" hooks, pulleys, screw-eyes, and all necessary hardware for easy installation.

## Accessories

### DOG-BONE COUNTERWEIGHT

Outer shell shall be made of high density polyethylene. Each counterweight shall have a threaded steel insert molded in to the upper end to accommodate a supplied 3/8" galvanized steel eyebolt. Shot shall be securely contained inside the outer shell to reach the desired weight.

### PICKWICK® DOG-OPERATED DOOR

Outside frame shall be 5/16" thick solid cast aluminum, swinging door shall be 1/4" thick clear polycarbonate sheet. Plated spring hinges are used on both doors. Shims and all mounting hardware not included.

### ALUMINUM FRAMED FRP SWING-UP REST BENCH

Bench surface shall be constructed of .030" FRP or High Pressure Wilsonart Laminate bonded on each side of a .400" HDPE substrate. The outer framework of the bench shall consist of 6063-T6 aluminum extrusions. All intersections are to be secured with aluminum angles and stainless steel flat head screws. The vertical front debris guard shall consist of 1' grid polyethylene structural foam 7/16" thick and run the width of the bench. The debris guard shall be connected to the bottom of the bench with stainless steel bolts and nuts. Bench shall be designed to pivot up and remain in the upright position until it is manually released and lowered. Bench shall be provided with all necessary hardware for installation.

### TUBULAR FRAME REST BENCH

Frame and legs shall be made from 1.05" O. D. Gatorshield® tubing. Resting area shall be made from ABS plastic .250" thick and fastened by aluminum keyhole clamps with stainless steel screws. All corners shall be precision welded, ground, cleaned, and covered with a zinc-rich coating containing at least 80% pure zinc when dried. A polypropylene plug shall be inserted in each leg. Standard sizes are regular 18" x 36" x 6", large 24" x 36" x 6", and extra large 24" x 48" x 6". Special sizes available. Specify free-standing or swing-up design.

### FABRIC SWING-UP REST BENCH

The outer framework of the bench shall consist of 6063-T6 aluminum extrusions. All intersections are to be TIG welded. The fabric is to be 40 oz. solid vinyl with plastic rod heat sealed into the edges. The fabric shall be secured to the outer frame with locking channels consisting of 6063-T6 aluminum extrusions and are attached to the outer frame with stainless steel bolts and stainless steel Nyloc nuts. The vertical front debris guard shall consist of 1' grid polyethylene structural foam 7/16" thick, and shall be connected to the bottom of the bench with stainless steel bolts and nuts. Bench shall be designed to pivot up and remain in the upright position until it is manually released and lowered. Bench shall be provided with all necessary hardware for installation.

### ALUMINUM GUTTER COVERS

Gutter covers shall be constructed of .100" aluminum sheet. Each cover shall have two rubber floor pads mounted to the return flange of the cover, hardware shall be stainless steel. Retainer pendants shall be constructed of 14 gauge (.075") stainless steel. Offset mounting brackets shall be 14 gauge (.075") hot dipped galvanized steel. Gutter covers shall be provided with all necessary hardware for installation.

### STAINLESS STEEL BOWL INSERT

Insert shall be constructed of 1/4" diameter stainless steel wire. Inserts shall be secured in place with stainless steel screws. Bowl wires shall be MIG welded at all intersections. The bowl shall be retained in the insert by a swing down door that shall be made of 16 gauge (.060") stainless steel. The swing down door shall be held in the closed position by means of a stainless steel swing pendant made of 12 gauge (.105") stainless steel. Pendant shall be mounted to the enclosure with a stainless steel screw, Nyloc nut, and a nylon spacer.

### ROTARY BOWL INSERT

Insert shall be constructed of 1/8" thick 3003 Aluminum with a 180 grit finish. Joints to be resistance welded at flange overlaps. Central pivot shall be stainless steel fasteners through bronze bushings. Insert shall be retained in the open or closed positions by two pendants made of 304 stainless steel with stainless steel fasteners. 1 qt. capacity stainless steel bowls shall sit in provided holes in the insert upper surface. Each insert shall be mounted to the gate/stallfront by 304 stainless steel brackets with stainless steel fasteners.

### PLASTISOL RAISED FLOORS

Flooring shall be plastisol-coated expanded metal or woven wire in custom-sized flat sheeting or with welded legs (up to 3" high). Coating material shall be 94 Durometer Shore A Plastisol with a uniform coating thickness of 1/8". Coating shall contain a fungicide bacteria growth inhibitor. Hole size after coating shall be:

- Diamond pattern: 7/16" x 3/4"; 1/2" x 1"; or 3/4" x 1-1/2"
- Woven wire oblong: 7/16" x 2"







*Trusted Animal Housing Solutions*

[www.masonco.com](http://www.masonco.com)

513.543.5567 | 937.780.2321