



Trusted Animal Housing Solutions

Introduction

Thank you very much for your investment in Mason kennels. At Mason we take great pride in providing our customers with the highest quality animal enclosures combined with an enjoyable ordering experience. The following instructions will assist you with proper assembly, cleaning, and maintenance of your Mason kennels. It is important to follow these guidelines in order to receive the best results and maximum life from your investment.

Assembly

The following pages will show you how to assemble your new Mason kennel. Since every order is custom built to your specifications, the instructions are designed to show the various methods used to assemble our kennels and some of the demonstrations may not apply to your order. Be sure to use the enclosed scale drawings at the end of this document of the provided hardware to ensure proper identification and usage.

Hardware

Depending on your Kennel project you may have some or all of the following hardware:

Part #	Description	Part #	Description
1344	¼" X 1- 1/4" Hex Head Tapcons	6223	5/16" x 1.5" Ball Lock Pin
6053	Upper Hinge Block	6222	5/16" x 2.5" Ball Lock Pin
6054	Lower Hinge Block	5542	5/16-18 Hex Flanged Nut

Note: Wall mounting hardware is shown only for reference purposes and is not included

Required Installation Tooling

- Level (4' preferred)
- 9/16" Combination wrench - (2) required
- 7/32" Masonry bit
- Tape measure
- Hammer drill
- Variable Speed Drill (cordless preferred)
- 5/16" Nut driver bit
- Tape measure

Section A Panel Identification

Refer to the floor plan supplied. Depending on the nature of your Kennel Project you will have either letter and or number designations on the tag(s) wired to the top of the panel as shown in Figure 1.

A

Figure 1

Section B Run Assembly

1. Refer to the floor plan and select a starting point for assembling the runs which is best for your application. Once selected, identify the exact location of the wall for the first wall support angle. Continue along the wall, marking where all of the wall support angles will go.
2. Starting from the point you selected in step B-1 place the first “wall support angle” against the wall. Make sure that you have the correct end at the floor. See figure 2.

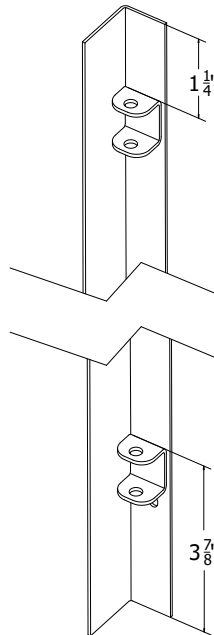

Figure 2

3. **Note: this system is not compatible with floor coves. If the wall you are mounting the system to has coving, it must be cut away for the system to be installed. The “wall support angles” must go all the way to the floor. See figure 3.**

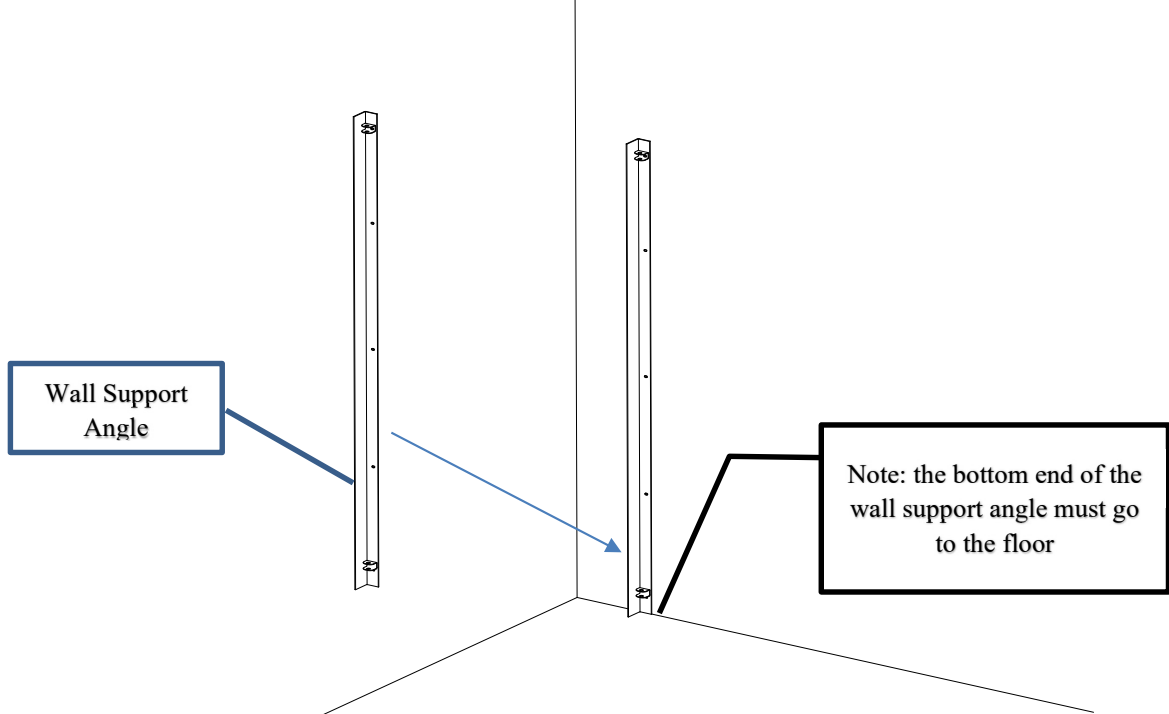

Figure 3

4. Using a level, plumb the angle. Using the pre-punched holes in the back flange wall support angles as a template, mark the wall through each hole. When all the holes are marked set the angle aside.
5. Drill a 3/16" hole at least 1-1/4" deep at each point mark in step B-4.
6. Realign the angle over the holes and using 1/4" X 1-1/4" hex head Tapcon screws (not provided), apply a screw in each hole in the flange of the angle that is against the wall.
7. Repeat steps C-3 through C-5 to assemble all of the wall support angles to the wall.
8. **If the wall you are mounting to is not plumb you will need to shim the angle until it is plumb.**

Section D Installing the Division Panels

1. Position and secure the first division panel using the supplied tapered hinge blocks, one 5/16" x 2.5" pin for the top and one 5/16" x 1.5" pin for the bottom. Note the shape and orientation of the support blocks. See Figure 4 and Figure 5.

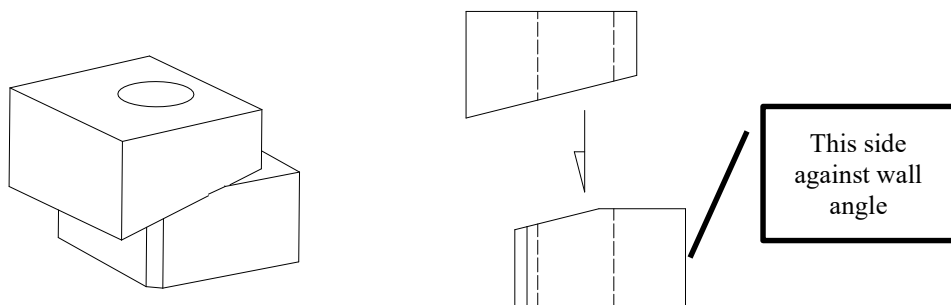

Figure 4

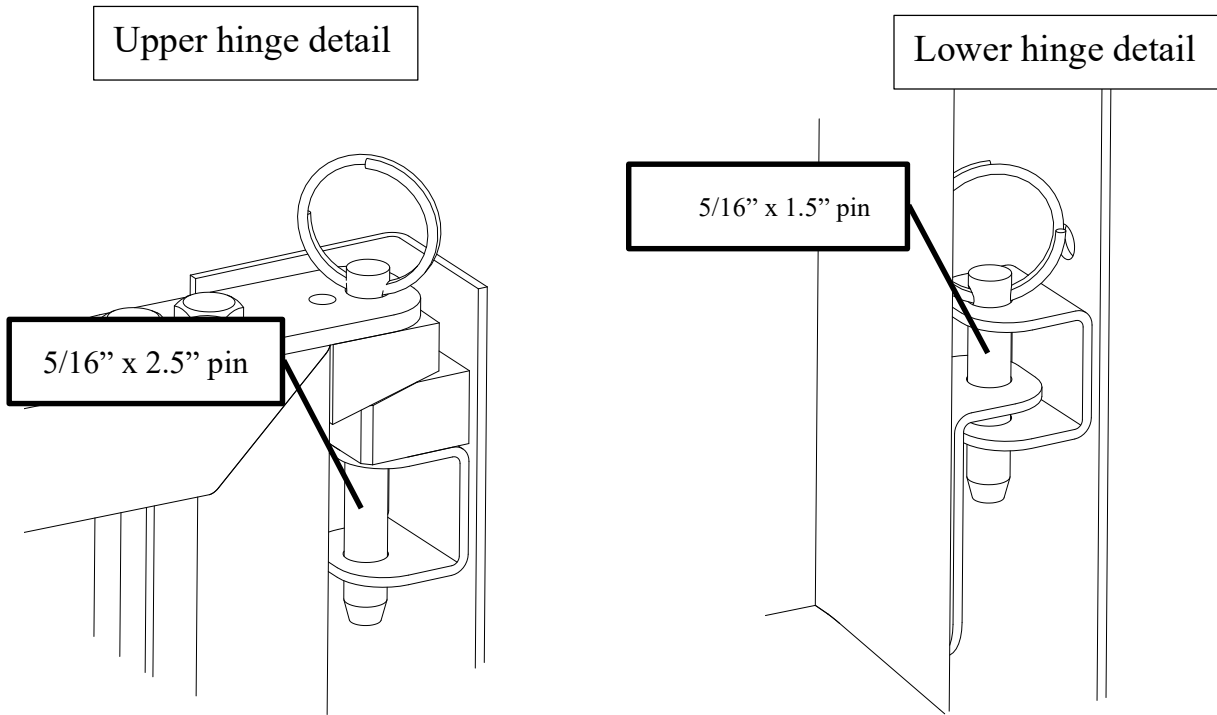

Figure 5

2. Repeat step D-1 for all division panels.

Section E

Gate / Stall Front Hanging

1. Attach a swivel caster to the bottom corners of each gate using 3/8\"/>

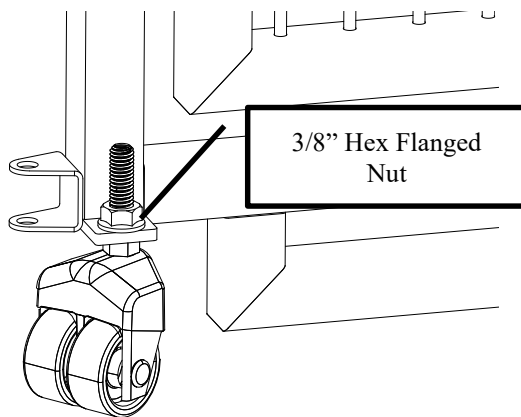

Figure 6

2. Beginning at one end of the system place a gate at the end of the division panel and secure using two 5/16\"/>

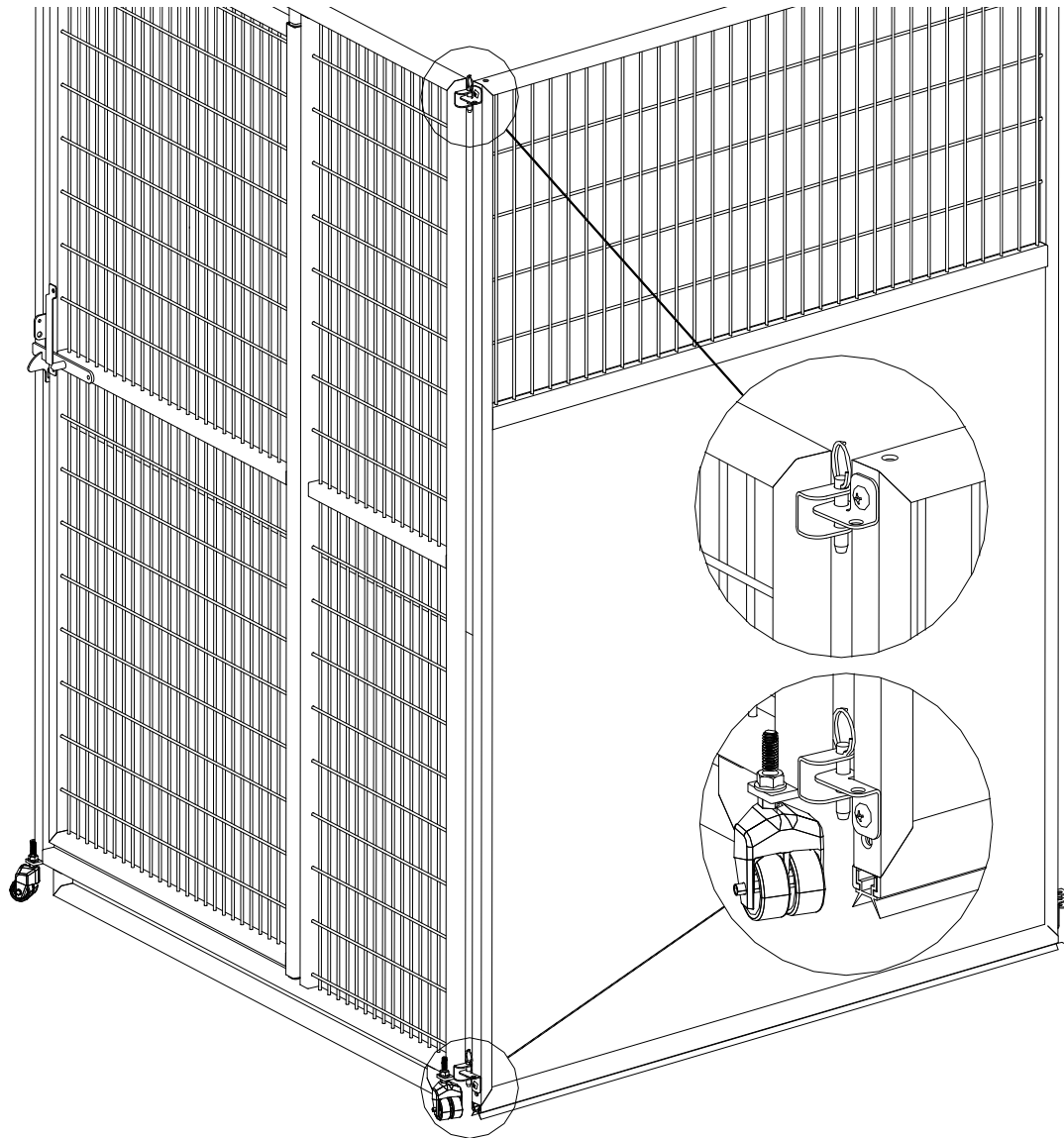

Figure 7

3. Position the gate and panel against the wall using the opposite edge of the gate to push the panel to the wall, continue swinging until the gate is against the wall. See Figure 8.

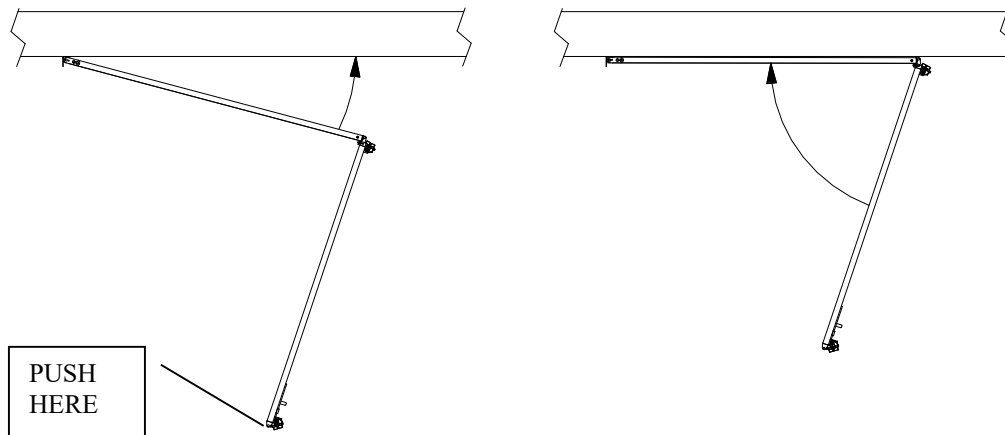

Figure 8

4. Repeat steps 2 and 3 for all gates.

Section H Gate / Stall Front Adjustment

During shipment and installation, gate assemblies may be forced out of adjustment. If your gate does not latch automatically when pushed closed, the latch can be adjusted by following these instructions.

Stainless Steel Gate / Stall Front (Reference Figure 9)

1. Loosen the latch catch bolts just enough to allow the latch catch to slide up and down.
2. Tap the latch catch up or down until the inside latch bar handle rests on the inside of the keeper and the latch bar rests in the bottom of the latch catch. Tighten latch catch bolts.

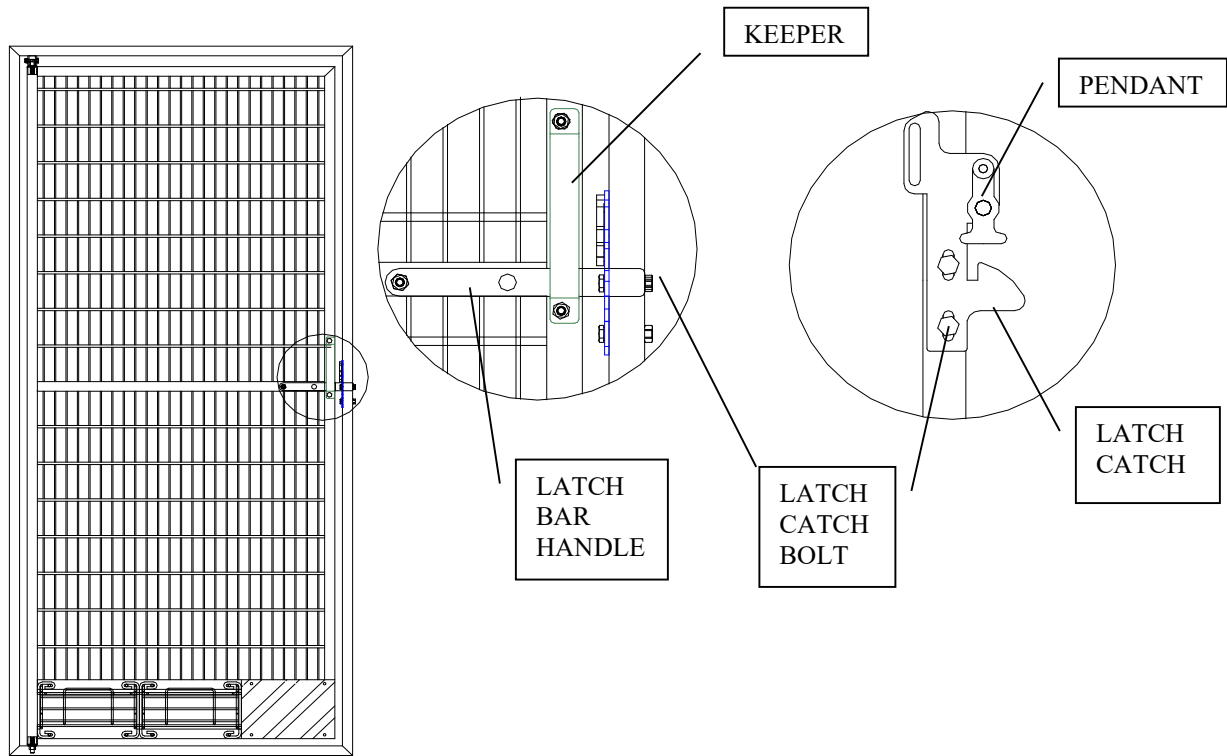

Figure 9

Panel Height Adjustment

1. Minor adjustments can be made to the division panels to adjust the pressure being applied to the floor seal. Your division panels are built with extra washers that can be used for this purpose. Remove the top bolts, remove the washers, and re-install the bolts. See figure 10.

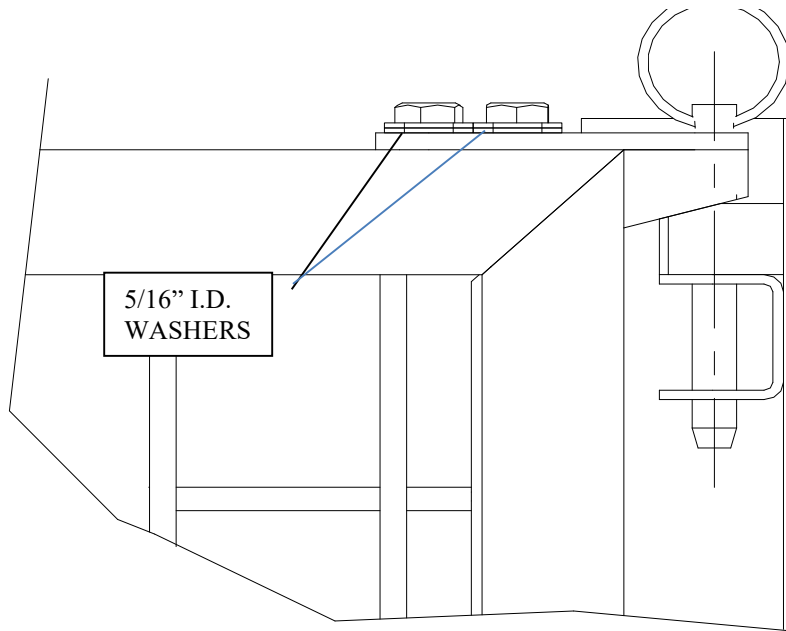

Figure 10

2. To raise the panel remove the washers shown in figure 10. These 5/16" I.D. washers can be inserted below the lower hinge block as needed. See figure 11.

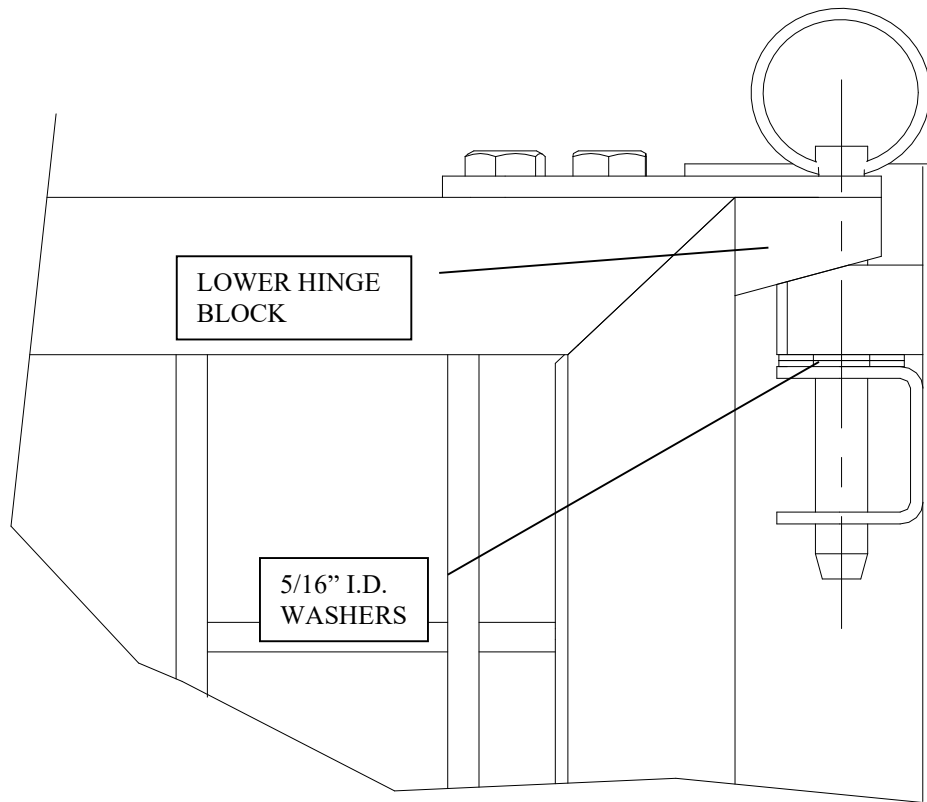

Figure 11

3. To lower the panel 5/16" I.D. washers can be inserted below the top mounting bracket on the division panel using a 7/16" wrench. See figure 12.

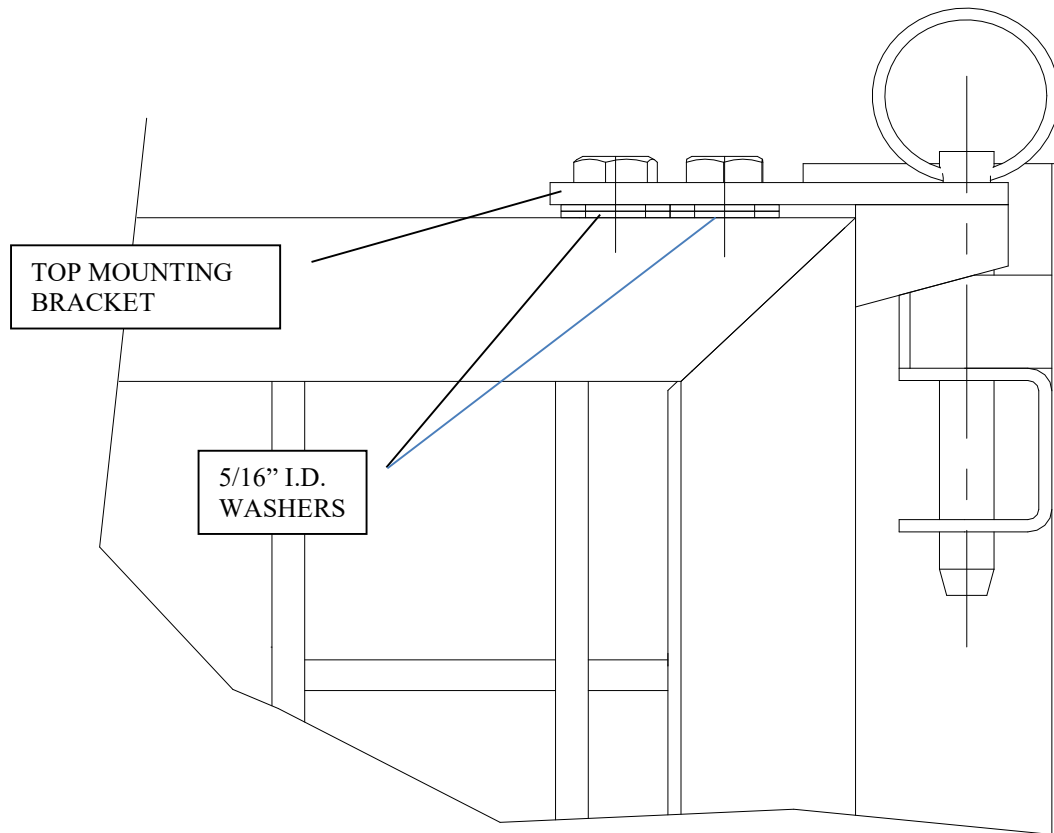

Figure 12

System Operation

1. To use your system start from the left hand side of the system. Pull out the end panel until it is perpendicular to the building wall.
2. Using the unattached edge of the left most gate, pull it out until the panel is perpendicular to the building wall.
3. Continue moving the gate until the attachment holes line up.
4. Install two 5/16" x 1 1/2" pins to secure the gate.
5. Lift and rotate Corner Brace and drop onto stud in Isolation Panel to fully secure system. See Figures 13 and 14.

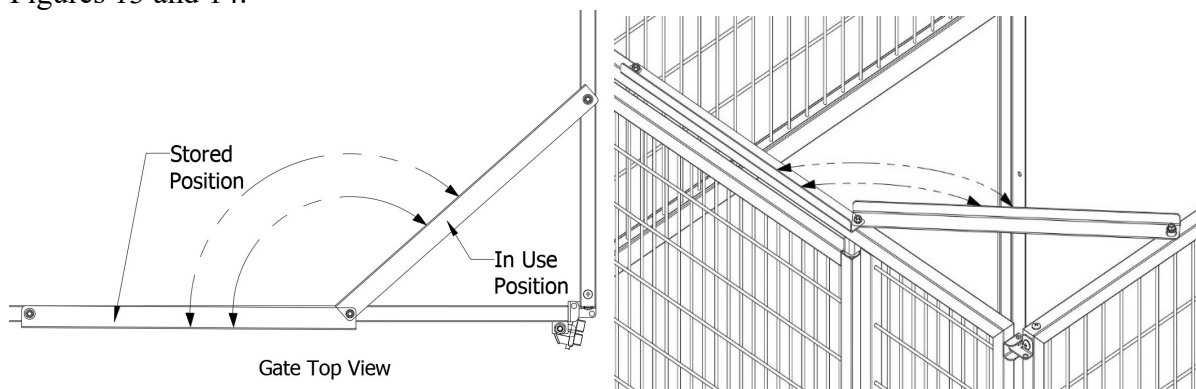

Figure 13 and 14

6. Continue using the remaining gates to setup each run needed.
7. Reverse the above sequence to fold the system back to the building wall.

Maintenance

Over time, your Mason kennels might require adjustments, lubrication, or replacement parts in order to remain in top working condition. We recommend a yearly maintenance schedule to lubricate door hinges, adjust gate locks and any other moving parts. A standard, industrial grease works well. If your kennels should need any replacement parts, our professional sales engineers will be happy to review your original order and assist you.

1/4" x 1 1/4" TAPCON
PART # - 1344



5/16" FLANGED HEX NUT
ID# 5542

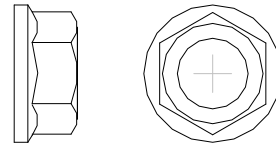

ID# 6222
5/16" X 2 1/2" BALL LOCK PIN

ID# 6223
5/16" X 1 1/2" BALL LOCK PIN

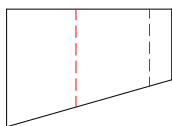
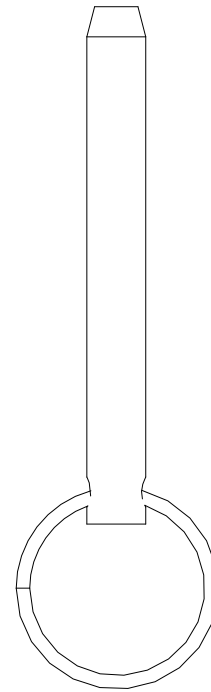
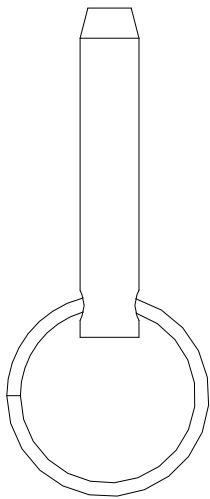

ID# 6053
UPPER HINGE
BLOCK

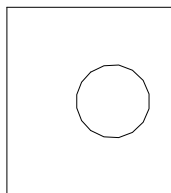

ID# 6054
LOWER HINGE
BLOCK

