



**MASON
COMPAI**

Designers and Manufacturers

Installation Instructions for Rotary Stainless Steel Bowl Brackets in Stainless Steel Gates

1. Place a 1/4-20 x 1" stainless steel truss head screw through (1) mounting bracket and (1) bronze bearing. Insert the screw assembly through the top of the main bowl insert. Note: the bearing should be a snug fit in the bowl insert. Using a 7/16" wrench and a Philipps screwdriver, install a 1/4-20 Nyloc nut onto the screw and tighten. In the same manner install a screw assembly to the bottom of the main bowl insert. See figure 1. Note that the brackets must be oriented as shown below.

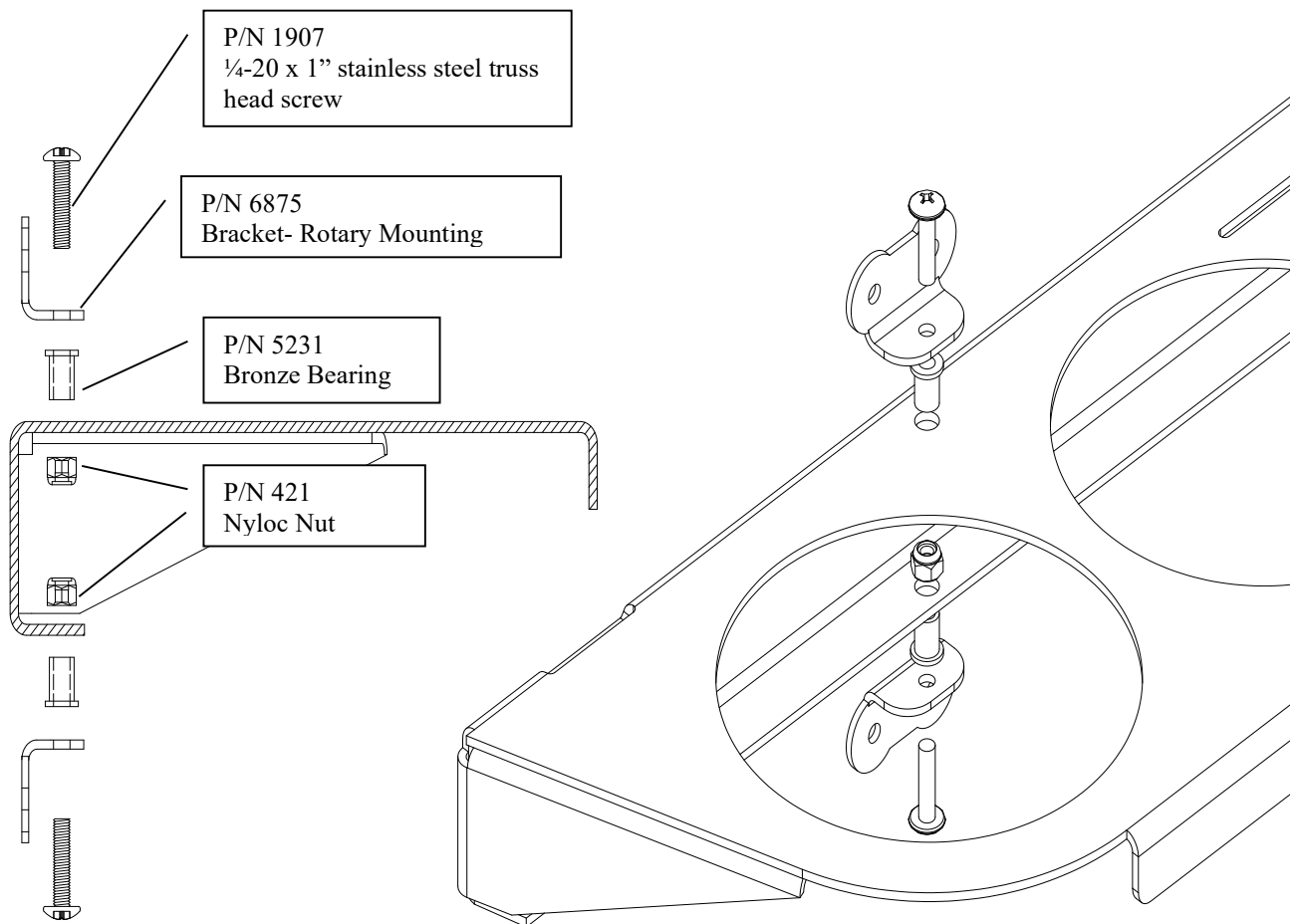
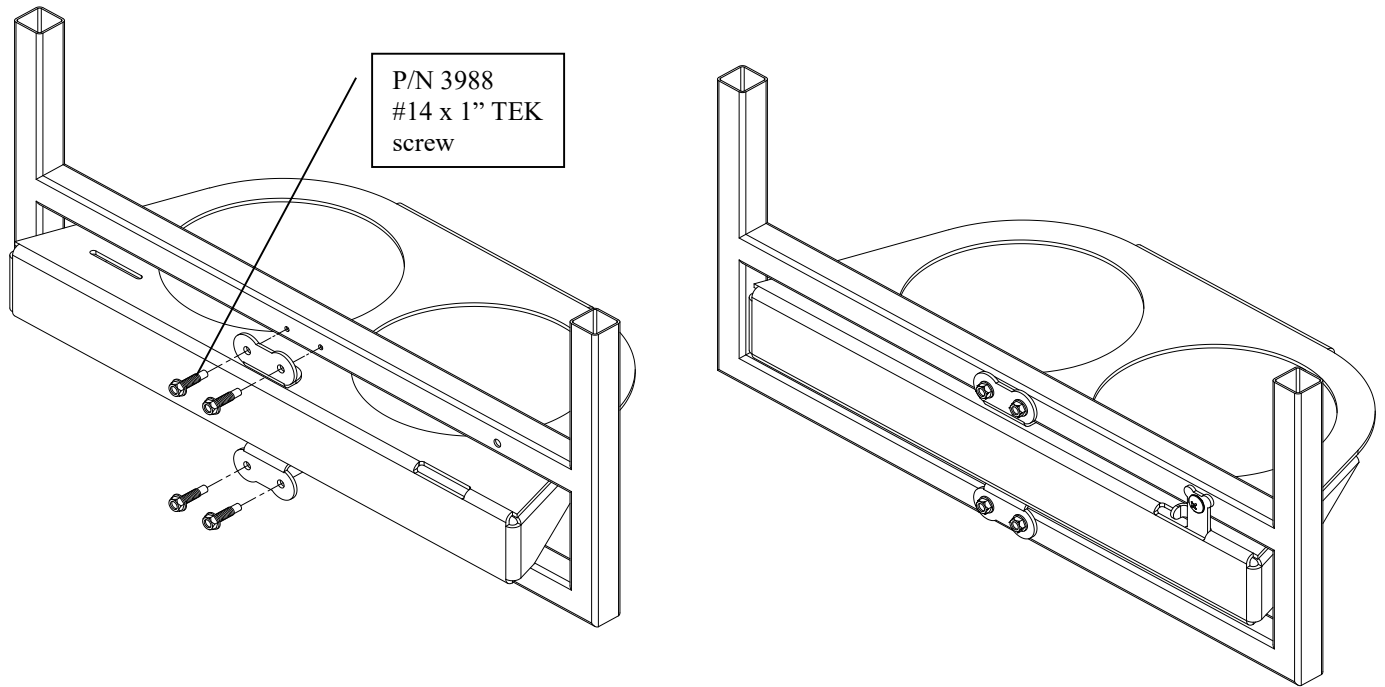

Figure 1

2. Place the bowl insert assembly into the gate opening. Align the mounting holes in the brackets with the pre-drilled holes in the gate. After ensuring that the bowl insert is aligned properly in the opening use (4) #14 x 1" TEK screws to secure the mounting brackets to the gate. See figure 2.



P/N 3988
#14 x 1" TEK
screw

Figure 2

3. Install (1) pendant by inserting a 1/4-20 x 1.5" stainless steel screw through the pendant and then into the hole provided in the gate. Place a 1/4-20 Stainless steel Nyloc nut on the screw. Using two 7/16" wrenches, tighten the nut until the pendant starts to bind. Back the nut off slightly until the pendant just starts to move freely. See figure 3.

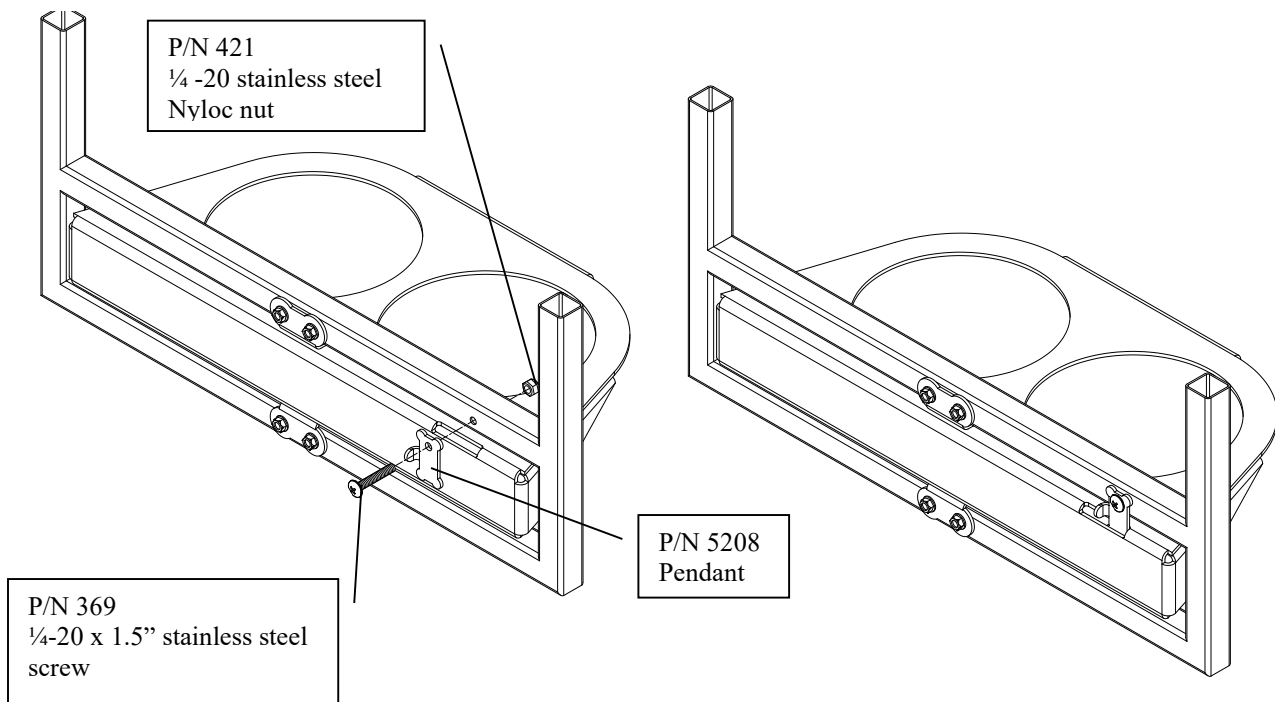

P/N 421
1/4 -20 stainless steel
Nyloc nut

P/N 5208
Pendant

P/N 369
1/4-20 x 1.5" stainless steel
screw

Figure 3